

BXTG13



smart hot runner solutions

www.mastip.com

Tip and Material Grade Availability

Tip (Code)	G1	G2	G5
Multi-hole Torpedo Tip (X 13 TT)	✓	✓	✓
One-hole Torpedo Tip (X 13 IT)	✓	✓	✓
Open Tip (X 13 OT)	✓	✗	✗

To order a nozzle assembly:

Provide the Nozzle Code + Grade
 (Order example: BXIT13175 G5)

To order a tip:

Provide the Tip Code + Grade
 (Order example: X 13 IT G5)

Nozzle Dimensions

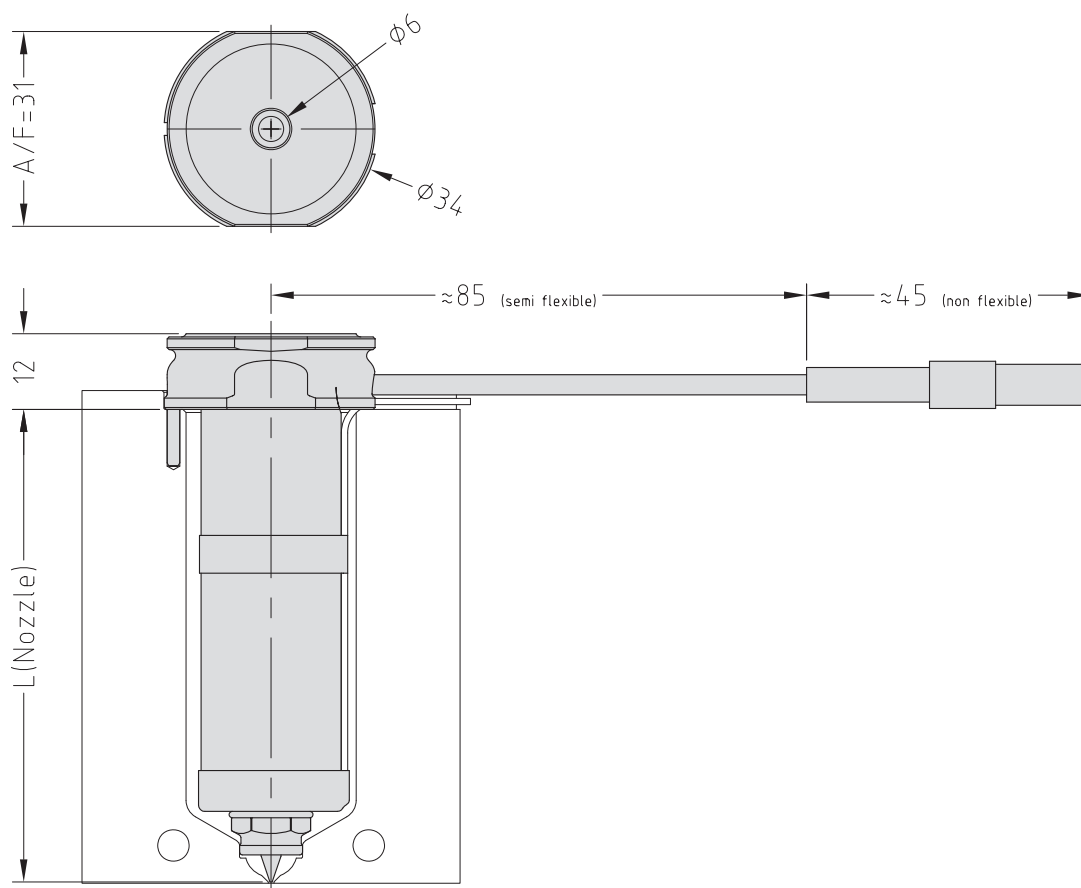

Multi-Hole Torpedo Nozzle Code	One-hole Torpedo Nozzle Code	Open Tip Nozzle Code	L	$E @ \Delta T = 200C$	$E @ \Delta T = 250C$
BXTT13045	BXIT13045	BXOT13045	45	0.12	0.15
BXTT13055	BXIT13055	BXOT13055	55	0.15	0.18
BXTT13065	BXIT13065	BXOT13065	65	0.17	0.21
BXTT13075	BXIT13075	BXOT13075	75	0.20	0.25
BXTT13095	BXIT13095	BXOT13095	95	0.25	0.31
BXTT13115	BXIT13115	BXOT13115	115	0.30	0.38
BXTT13145	BXIT13145	BXOT13145	145	0.38	0.48
BXTT13175	BXIT13175	BXOT13175	175	0.46	0.58

Nozzle Fitment and Gate Dimensions

$$E = L \times 0.0000132 \times (\text{nozzle temp. } ^\circ\text{C} - \text{mould temp. } ^\circ\text{C})$$

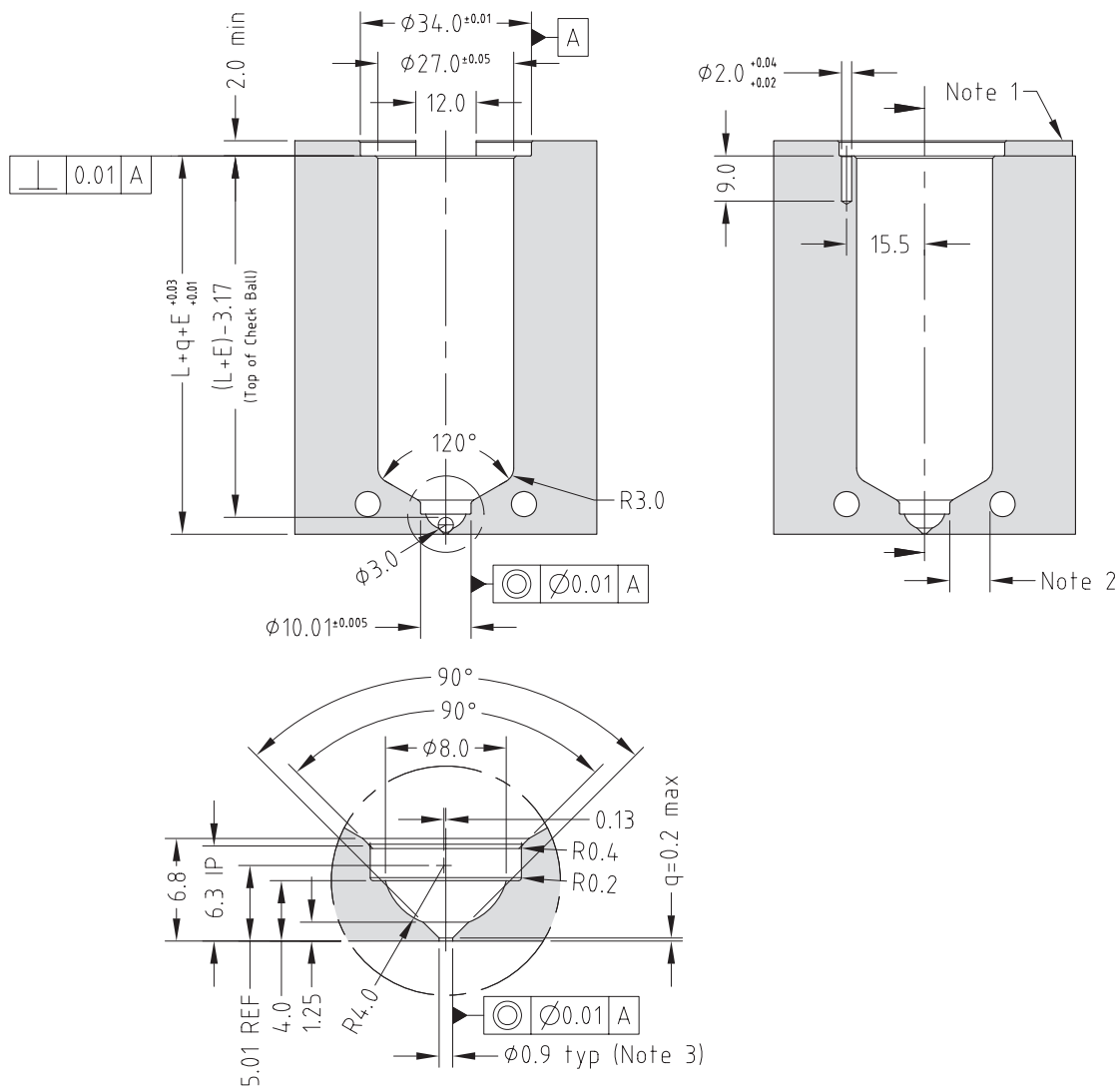

Note

1. Wire channel to suit mould.
 2. Gate cooling is critical for correct operation and gate quality. → See Cooling section in Technical Specifications.
 3. Modify gate diameter and land to suit the part. → See Gate Modifications in Technical Specifications.
- * Minimum strength (σ_y) of nozzle plate 800MPa.

Tip and Material Grade Availability

Tip (Code)	G1	G2	G5
Multi-hole Torpedo Tip (X 13 TT)	✓	✓	✓
One-hole Torpedo Tip (X 13 IT)	✓	✓	✓
Open Tip (X 13 OT)	✓	×	×

Bush Nut Options

- BN - Standard bush nut
- BE - Full-contact bush nut*

The nozzle codes listed to the right are for nozzle assemblies with a standard bush nut. To order a full-contact bush nut, replace the BN in the code with BE.

To order a nozzle assembly:

Provide the Nozzle Code + Grade
(Order example: BXIBN13175 G5)

To order a tip:

Provide the Tip Code + Grade
(Order example: X 13 IT G5)

Nozzle Dimensions

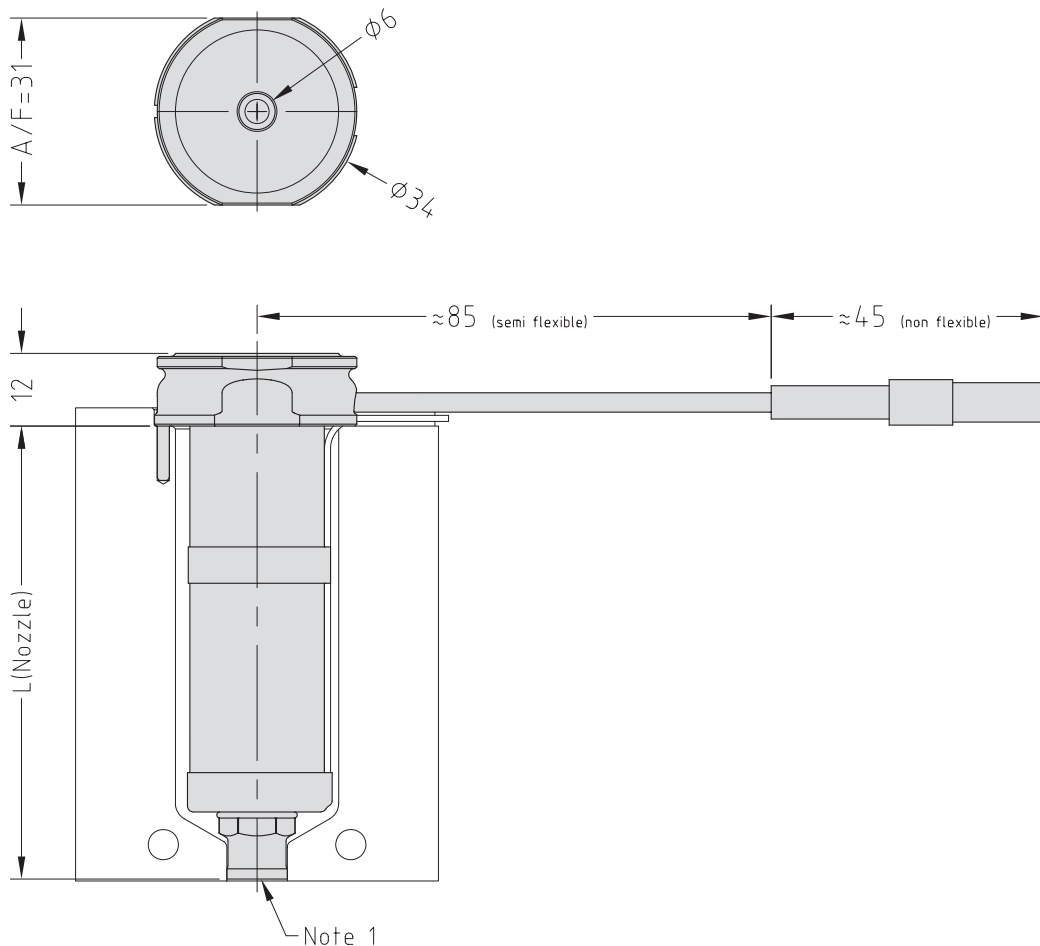
**Note**

1. Modify the contact area and the bush nut to suit the application.

→ See Gate Modifications and Cooling sections in the Technical Specifications.

Multi-hole Torpedo Tip Nozzle Code	One-hole Torpedo Tip Nozzle Code	Open Tip Nozzle Code	L	$E@ΔT = 200C$	$E@ΔT = 250C$
BXTBN13045	BXIBN13045	BXOBN13045	45.2	0.12	0.15
BXTBN13055	BXIBN13055	BXOBN13055	55.2	0.15	0.18
BXTBN13065	BXIBN13065	BXOBN13065	65.2	0.17	0.22
BXTBN13075	BXIBN13075	BXOBN13075	75.2	0.20	0.25
BXTBN13095	BXIBN13095	BXOBN13095	95.2	0.25	0.31
BXTBN13115	BXIBN13115	BXOBN13115	115.2	0.30	0.38
BXTBN13145	BXIBN13145	BXOBN13145	145.2	0.38	0.48
BXTBN13175	BXIBN13175	BXOBN13175	175.2	0.46	0.58

Nozzle Fitment and Gate Dimensions

$$E = L \times 0.0000132 \times (\text{nozzle temp. } ^\circ\text{C} - \text{mould temp. } ^\circ\text{C})$$

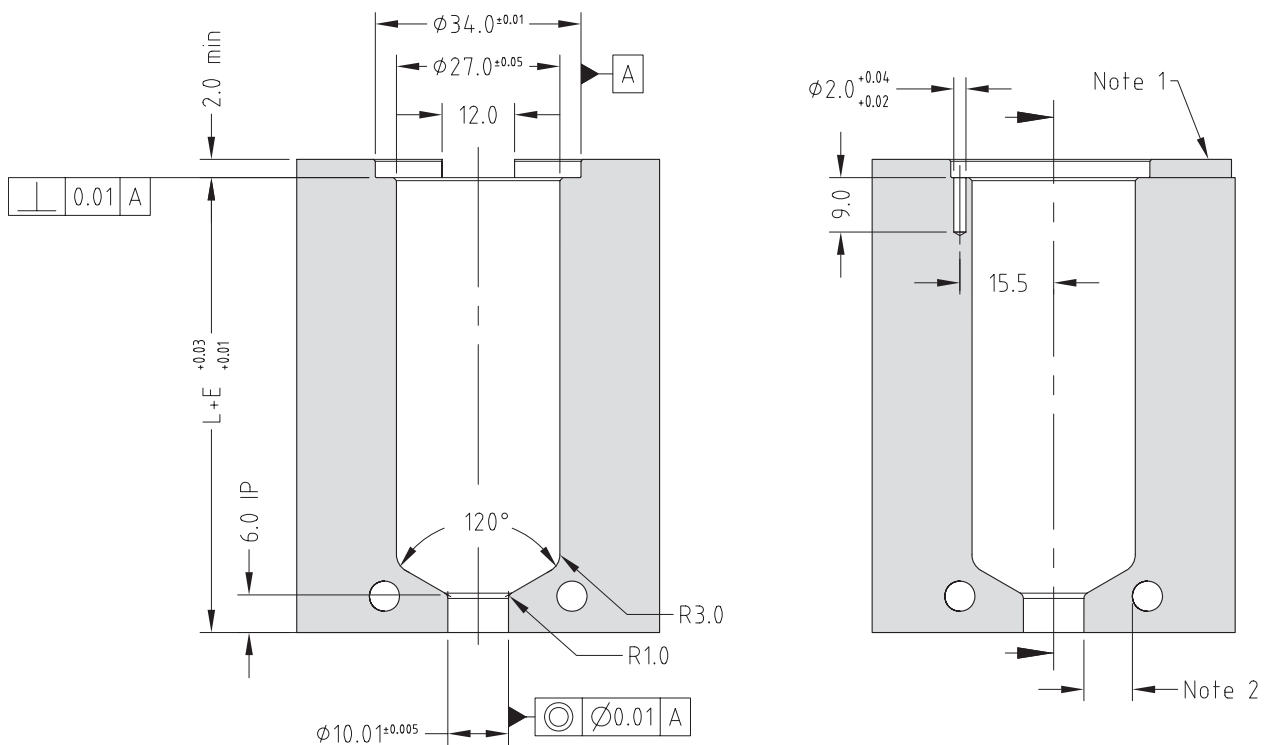

Note

1. Wire channel to suit mould.
 2. Gate cooling is critical for correct operation and gate quality. → See Cooling section in Technical Specifications.
 3. Modify gate diameter and land to suit the part. Supplied with $\phi 0.9$ → See Gate Modifications in Technical Specifications.
- * Minimum strength (σ_y) of nozzle plate 800MPa.

Tip and Material Grade Availability

Tip (Code)	G1	G2	G5
Multi-hole Torpedo Tip (X 13 TT)	✓	✓	✓
One-hole Torpedo Tip (X 13 IT)	✓	✓	✓
Open Tip (X 13 OT)	✓	×	×

To order a nozzle assembly:

Provide the Nozzle Code + Grade
(Order example: BXISN13175 G5)

To order a tip:

Provide the Tip Code + Grade
(Order example: X 13 IT G5)

Nozzle Dimensions

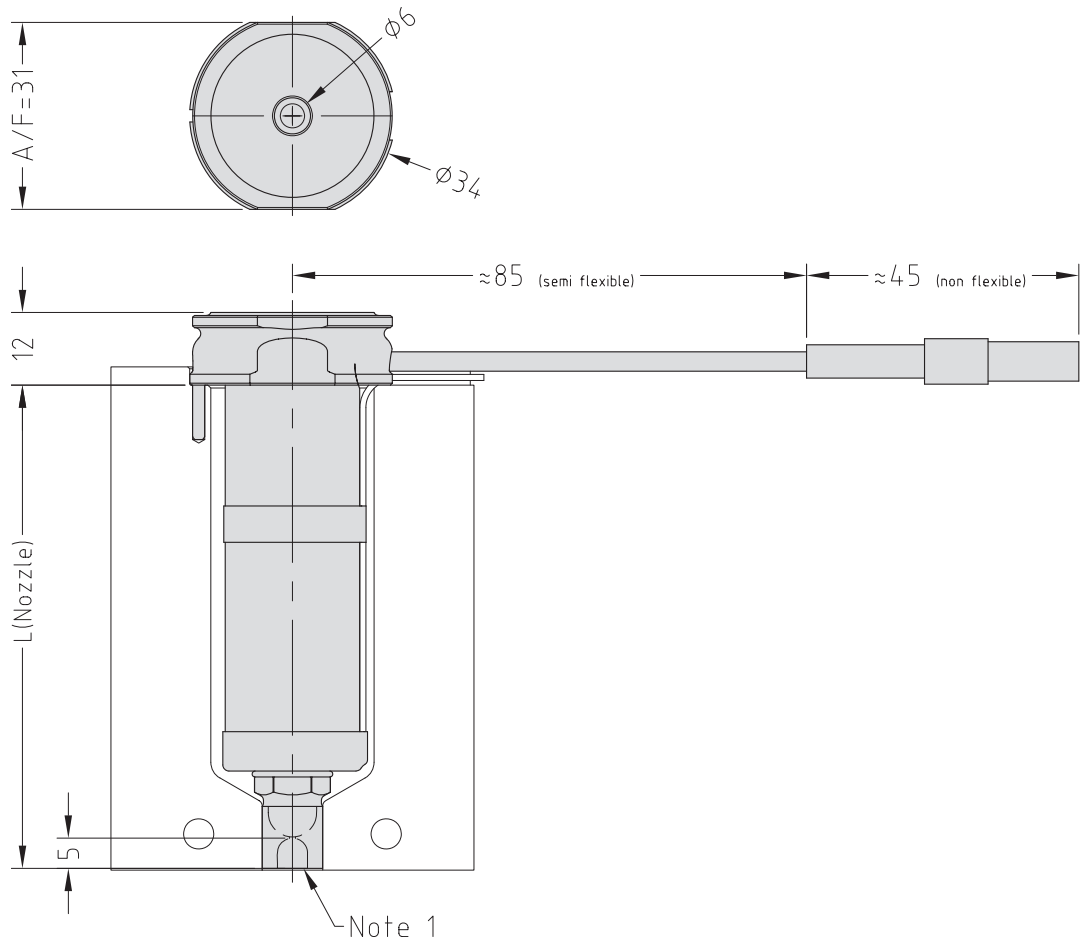
**Note**

1. Modify the contact area and the sprue nut to suit the application.
- See Gate Modifications and Cooling sections in the Technical Specifications.

Multi-hole Torpedo Tip Nozzle Code	One-hole Torpedo Tip Nozzle Code	Open Tip Nozzle Code	L	$E @ \Delta T = 200C$	$E @ \Delta T = 250C$
BXTSN13045	BXISN13045	BXOSN13045	50.2	0.13	0.17
BXTSN13055	BXISN13055	BXOSN13055	60.2	0.16	0.20
BXTSN13065	BXISN13065	BXOSN13065	70.2	0.19	0.23
BXTSN13075	BXISN13075	BXOSN13075	80.2	0.22	0.26
BXTSN13095	BXISN13095	BXOSN13095	100.2	0.26	0.33
BXTSN13115	BXISN13115	BXOSN13115	120.2	0.32	0.40
BXTSN13145	BXISN13145	BXOSN13145	150.2	0.40	0.50
BXTSN13175	BXISN13175	BXOSN13175	180.2	0.48	0.59

Nozzle Fitment and Gate Dimensions

$$E = L \times 0.0000132 \times (\text{nozzle temp. } ^\circ\text{C} - \text{mould temp. } ^\circ\text{C})$$

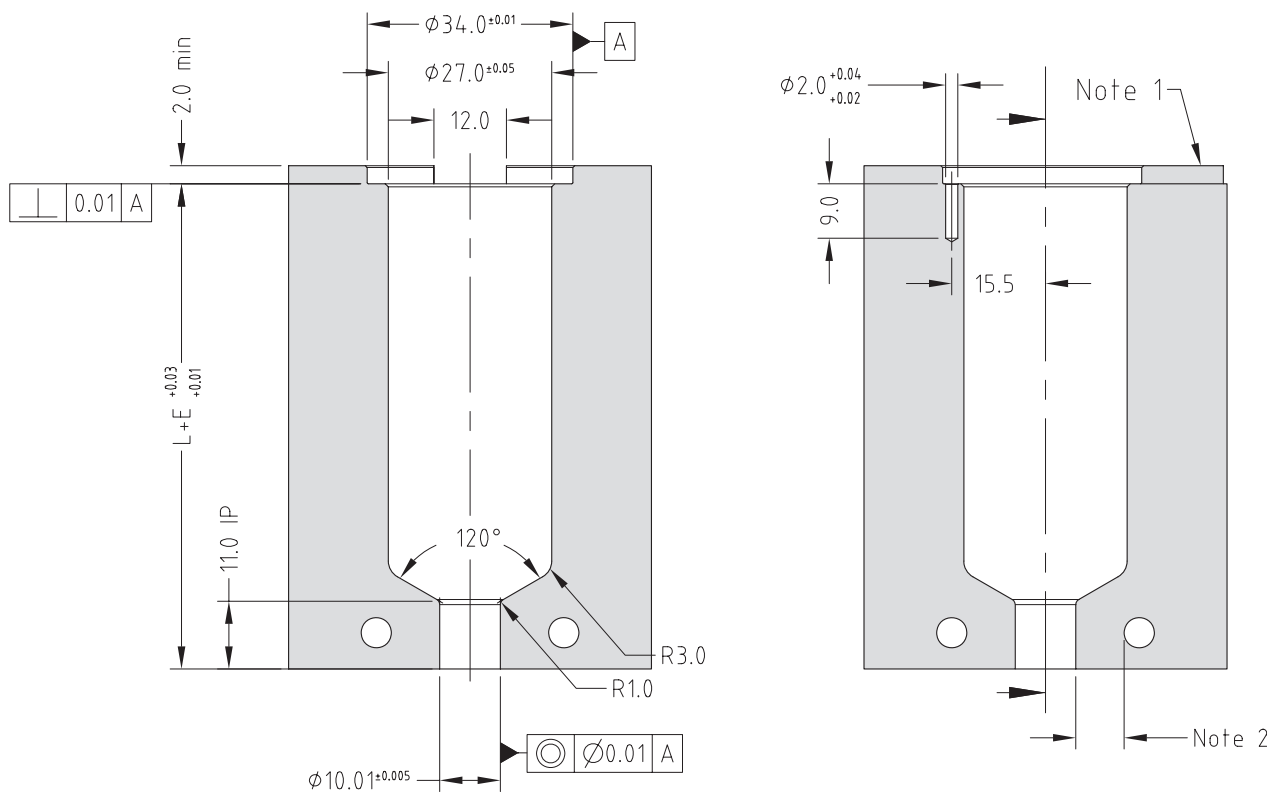

Note

1. Wire channel to suit mould.
 2. Gate cooling is critical for correct operation and gate quality. → See Cooling section in Technical Specifications.
 3. Modify gate diameter and land to suit the part. Supplied with $\emptyset 0.9$ → See Gate Modifications in Technical Specifications.
- * Minimum strength (σ_y) of nozzle plate 800MPa.

Tip and Material Grade Availability

Tip (Code)	G1	G2	G5
Multi-hole Torpedo Tip (X 13 TT)	✓	✓	✓
One-hole Torpedo Tip (X 13 IT)	✓	✓	✓
Open Tip (X 13 OT)	✓	×	×

To order a nozzle assembly:

Provide the Nozzle Code + Grade
(Order example: BXISX13175 G5)

To order a tip:

Provide the Tip Code + Grade
(Order example: X 13 IT G5)

Nozzle Dimensions

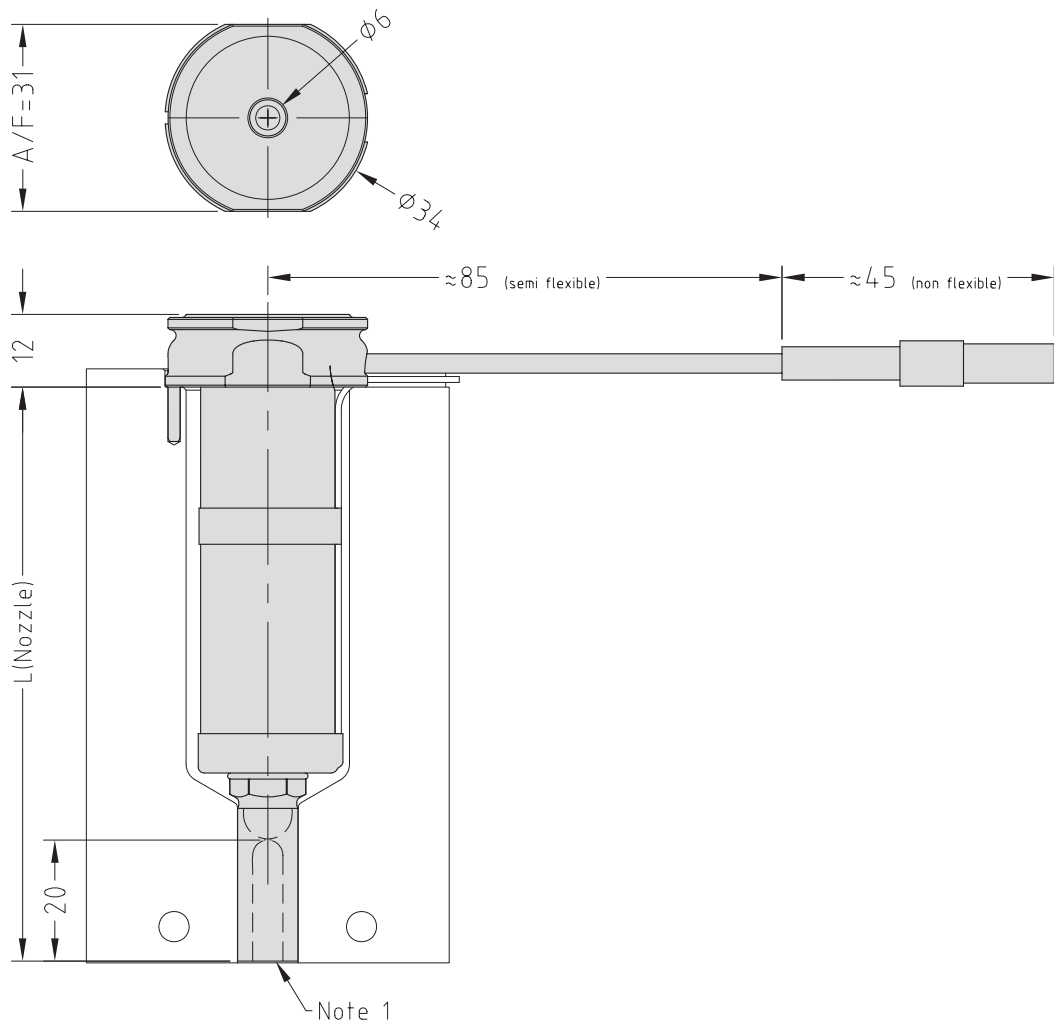
**Note**

1. Modify the contact area and the sprue nut to suit the application.
→ See Gate Modifications and Cooling sections in the Technical Specifications.

Multi-hole Torpedo Tip Nozzle Code	One-hole Torpedo Tip Nozzle Code	Open Tip Nozzle Code	L	$E @ \Delta T = 200C$	$E @ \Delta T = 250C$
BXTSX13045	BXISX13045	BXOSX13045	65.2	0.17	0.22
BXTSX13055	BXISX13055	BXOSX13055	75.2	0.20	0.25
BXTSX13065	BXISX13065	BXOSX13065	85.2	0.23	0.28
BXTSX13075	BXISX13075	BXOSX13075	95.2	0.25	0.31
BXTSX13095	BXISX13095	BXOSX13095	115.2	0.30	0.38
BXTSX13115	BXISX13115	BXOSX13115	135.2	0.36	0.45
BXTSX13145	BXISX13145	BXOSX13145	165.2	0.44	0.55
BXTSX13175	BXISX13175	BXOSX13175	195.2	0.52	0.64

Nozzle Fitment and Gate Dimensions

$$E = L \times 0.0000132 \times (\text{nozzle temp. } ^\circ\text{C} - \text{mould temp. } ^\circ\text{C})$$

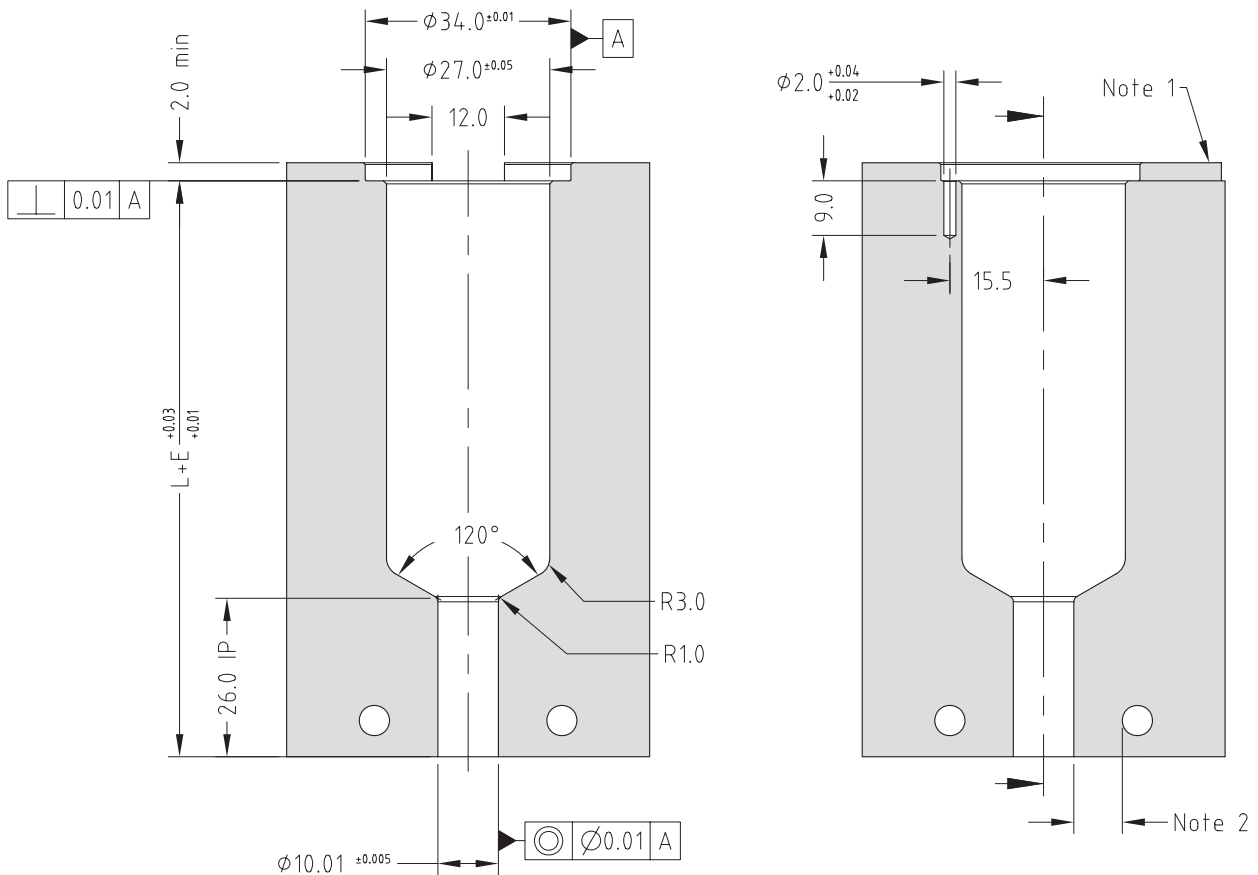

Note

1. Wire channel to suit mould.
 2. Gate cooling is critical for correct operation and gate quality. → See Cooling section in Technical Specifications.
 3. Modify gate diameter and land to suit the part. Supplied with $\emptyset 0.9$ → See Gate Modifications in Technical Specifications.
- * Minimum strength (σ_y) of nozzle plate 800MPa.

Tip and Material Grade Availability

Tip (Code)	G1	G2	G5
Multi-hole Torpedo Tip (X 13 TT)	✓	✓	✓
One-hole Torpedo Tip (X 13 IT)	✓	✓	✓
Open Tip (X 13 OT)	✓	×	×

To order a nozzle assembly:

Provide the Nozzle Code + Grade
(Order example: BXISL13175 G5)

To order a tip:

Provide the Tip Code + Grade
(Order example: X 13 IT G5)

Nozzle Dimensions

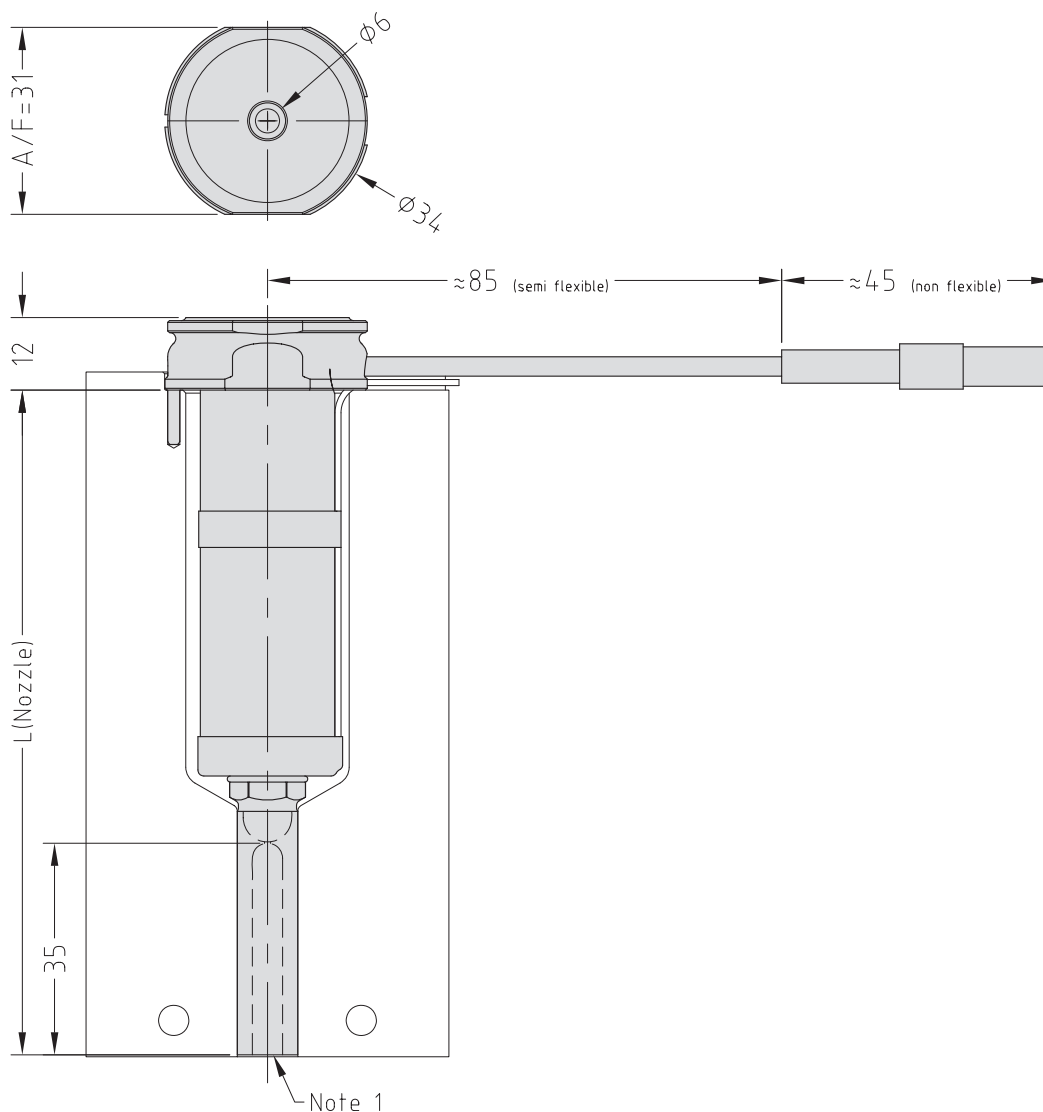
**Note**

1. Modify the contact area and the sprue nut to suit the application.
- See Gate Modifications and Cooling sections in the Technical Specifications.

Tip and Material Grade Availability

Tip (Code)	G1	G2	G5
Multi-hole Torpedo Tip (X 13 TT+5)	✓	✓	✗
One-hole Torpedo Tip (X 13 IT+5)	✓	✓	✗
Open Tip	✗	✗	✗

To order a nozzle assembly:

Provide the Nozzle Code + Grade
(Order example: BXIT13175+5 G2)

To order a tip:

Provide the Tip Code + Grade
(Order example: X 13 IT+5 G1)

Nozzle Dimensions

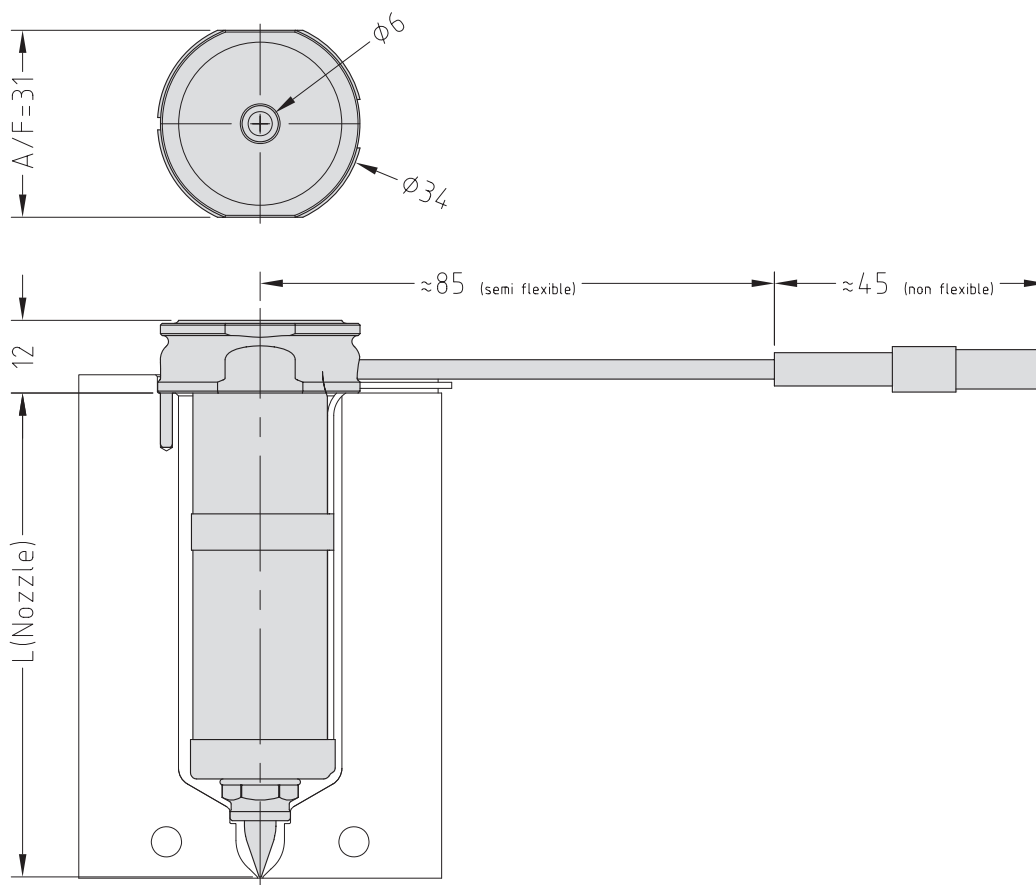

Multi-hole Torpedo Tip Nozzle Code	One-hole Torpedo Tip Nozzle Code	L	$E @ \Delta T = 200C$	$E @ \Delta T = 250C$
BXTT13045+5	BXIT13045+5	50	0.13	0.17
BXTT13055+5	BXIT13055+5	60	0.16	0.20
BXTT13065+5	BXIT13065+5	70	0.18	0.23
BXTT13075+5	BXIT13075+5	80	0.21	0.26
BXTT13095+5	BXIT13095+5	100	0.26	0.33
BXTT13115+5	BXIT13115+5	120	0.32	0.40
BXTT13145+5	BXIT13145+5	150	0.40	0.50
BXTT13175+5	BXIT13175+5	180	0.48	0.59

Nozzle Fitment and Gate Dimensions

$$E = L \times 0.0000132 \times (\text{nozzle temp. } ^\circ\text{C} - \text{mould temp. } ^\circ\text{C})$$

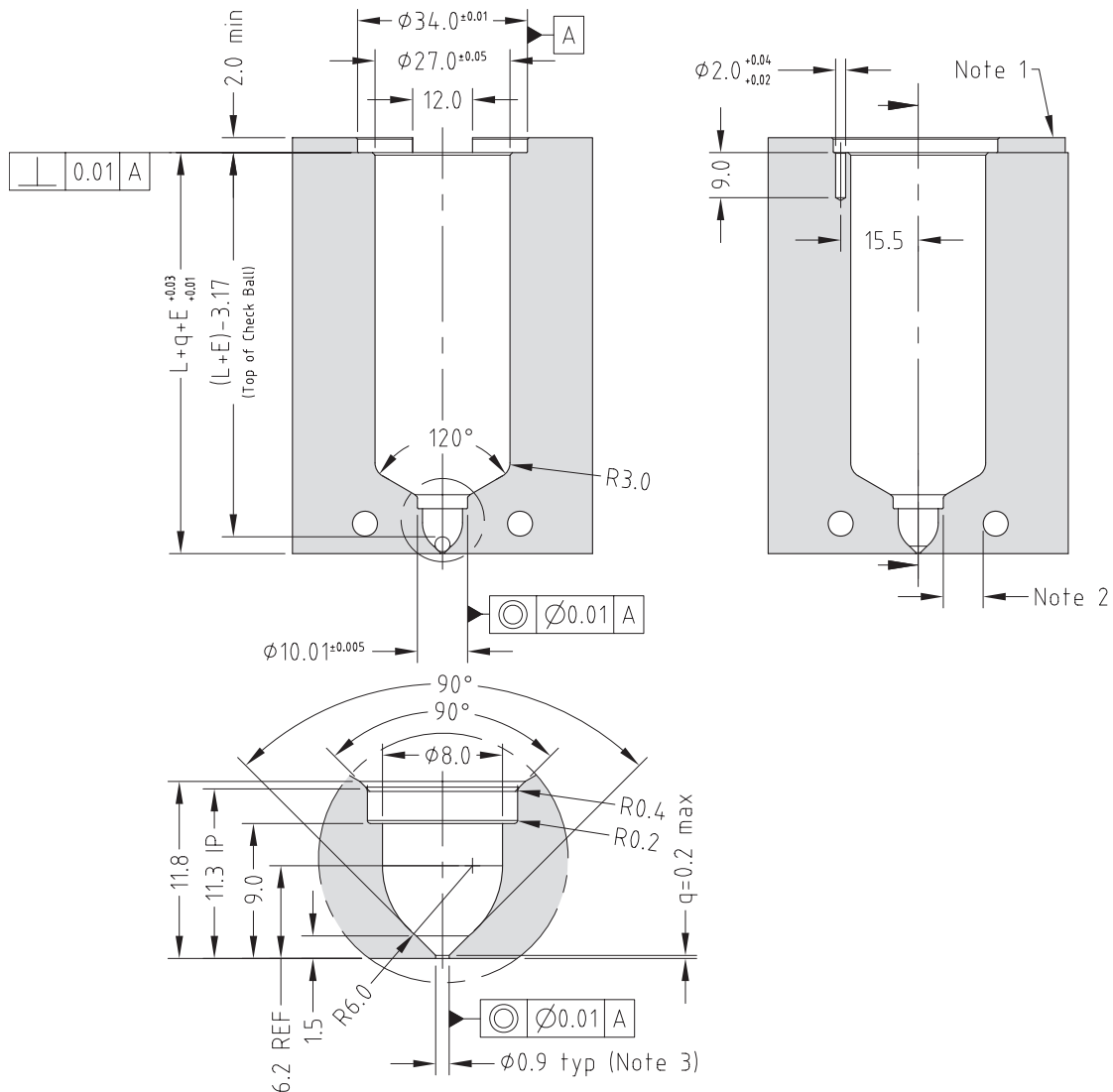

Note

1. Wire channel to suit mould.
 2. Gate cooling is critical for correct operation and gate quality. → See Cooling section in Technical Specifications.
 3. Modify gate diameter and land to suit the part. → See Gate Modifications in Technical Specifications.
- * Minimum strength (σ_y) of nozzle plate 800MPa.

Tip and Material Grade Availability

Tip (Code)	G1	G2	G5
Multi-hole Torpedo Tip (X 13 TT+10)	✓	✓	✗
One-hole Torpedo Tip (X 13 IT+10)	✓	✓	✗
Open Tip	✗	✗	✗

To order a nozzle assembly:

Provide the Nozzle Code + Grade
(Order example: BXIT13175+10 G2)

To order a tip:

Provide the Tip Code + Grade
(Order example: X 13 IT+10 G1)

Nozzle Dimensions

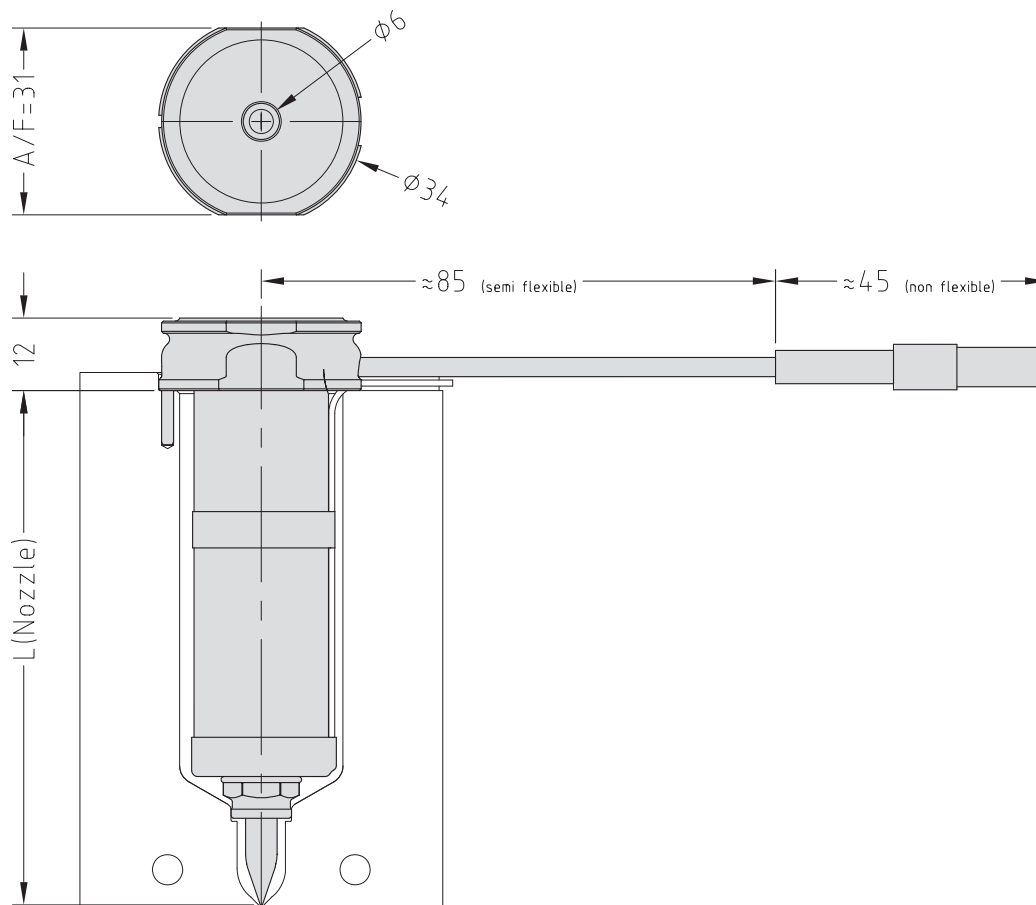

Multi-hole Torpedo Tip Nozzle Code	One-hole Torpedo Tip Nozzle Code	L	EQΔT =200C	EQΔT =250C
BXTT13045+10	BXIT13045+10	55	0.15	0.18
BXTT13055+10	BXIT13055+10	65	0.17	0.21
BXTT13065+10	BXIT13065+10	75	0.20	0.25
BXTT13075+10	BXIT13075+10	85	0.22	0.28
BXTT13095+10	BXIT13095+10	105	0.28	0.35
BXTT13115+10	BXIT13115+10	125	0.33	0.41
BXTT13145+10	BXIT13145+10	155	0.41	0.51
BXTT13175+10	BXIT13175+10	185	0.49	0.61

Nozzle Fitment and Gate Dimensions

$$E = L \times 0.0000132 \times (\text{nozzle temp. } ^\circ\text{C} - \text{mould temp. } ^\circ\text{C})$$

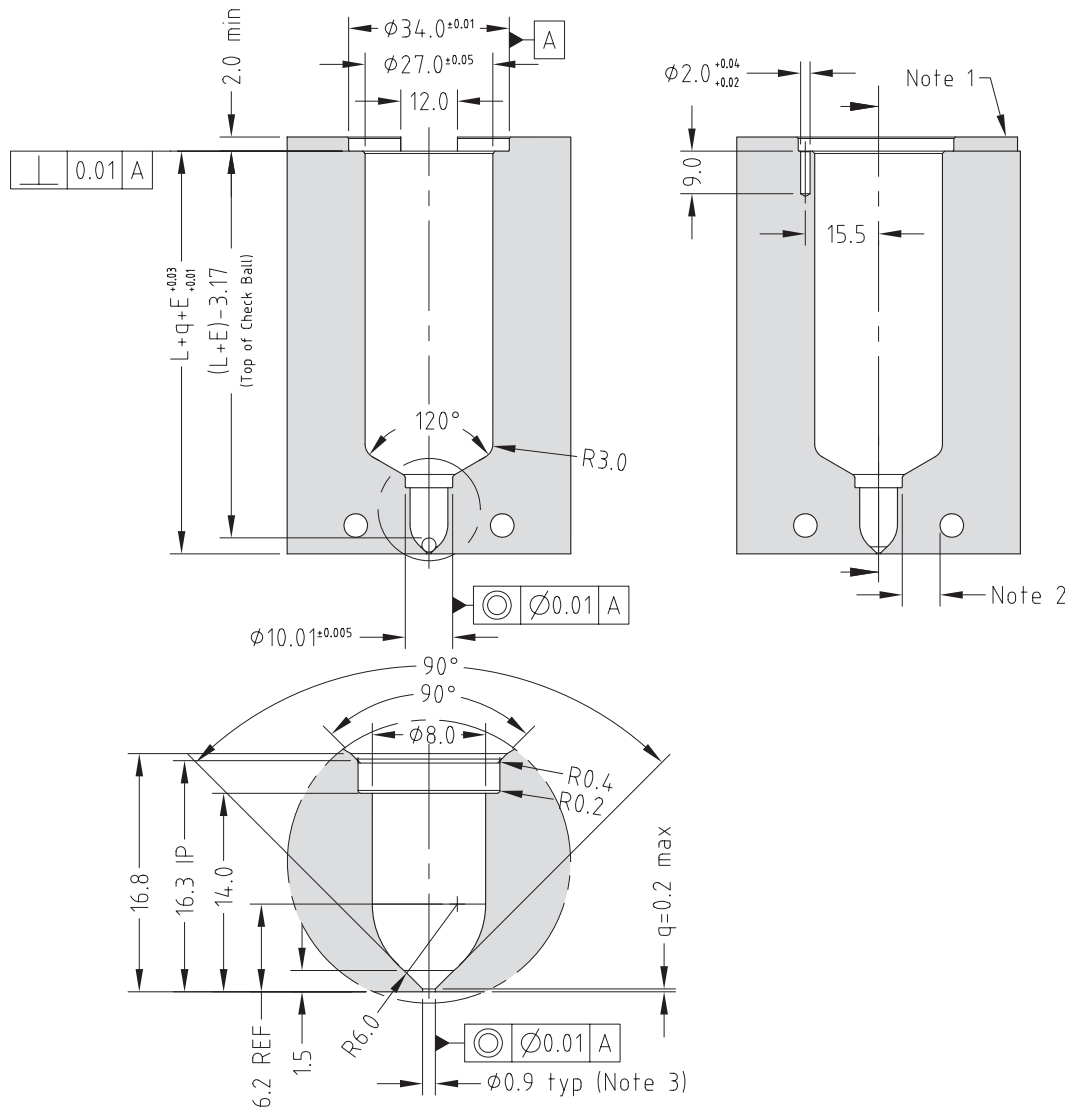

Note

1. Wire channel to suit mould.
 2. Gate cooling is critical for correct operation and gate quality. → See Cooling section in Technical Specifications.
 3. Modify gate diameter and land to suit the part. → See Gate Modifications in Technical Specifications.
- * Minimum strength (σ_y) of nozzle plate 800MPa.

Mastip Head Office New Zealand

558 Rosebank Road
Avondale 1026, Auckland
PO Box 90-651
Victoria Street West
Auckland 1142
New Zealand
Phone: +64 9 970 2100
Fax: +64 9 970 2070
Email: mastip@mastip.com

Mastip Regional Office Europe

Phone: +33 4 724 72 800
Fax: +33 4 724 72 801
Email: europe@mastip.com

Mastip Regional Office China

Phone: +86 21 644 77838
Fax: +86 21 644 77828
Email: china@mastip.com

Mastip Regional Office North America

Phone: +1 262 644 9400
Fax: +1 262 644 9402
Email: northamerica@mastip.com

40-000-000

V1.04



BXTG16



smart hot runner solutions

www.mastip.com

Tip (Code)	G1	G2	G5
Multi-hole Torpedo Tip (X 16 TT)	✓	✓	✓
One-hole Torpedo Tip (X 16 IT)	✓	✓	✓
Open Tip (X 16 OT)	✓	×	×

To order a nozzle assembly:

Provide the Nozzle Code + Grade
(Order example: BXIT16175 G5)

To order a tip:

Provide the Tip Code + Grade
(Order example: X 16 IT G5)

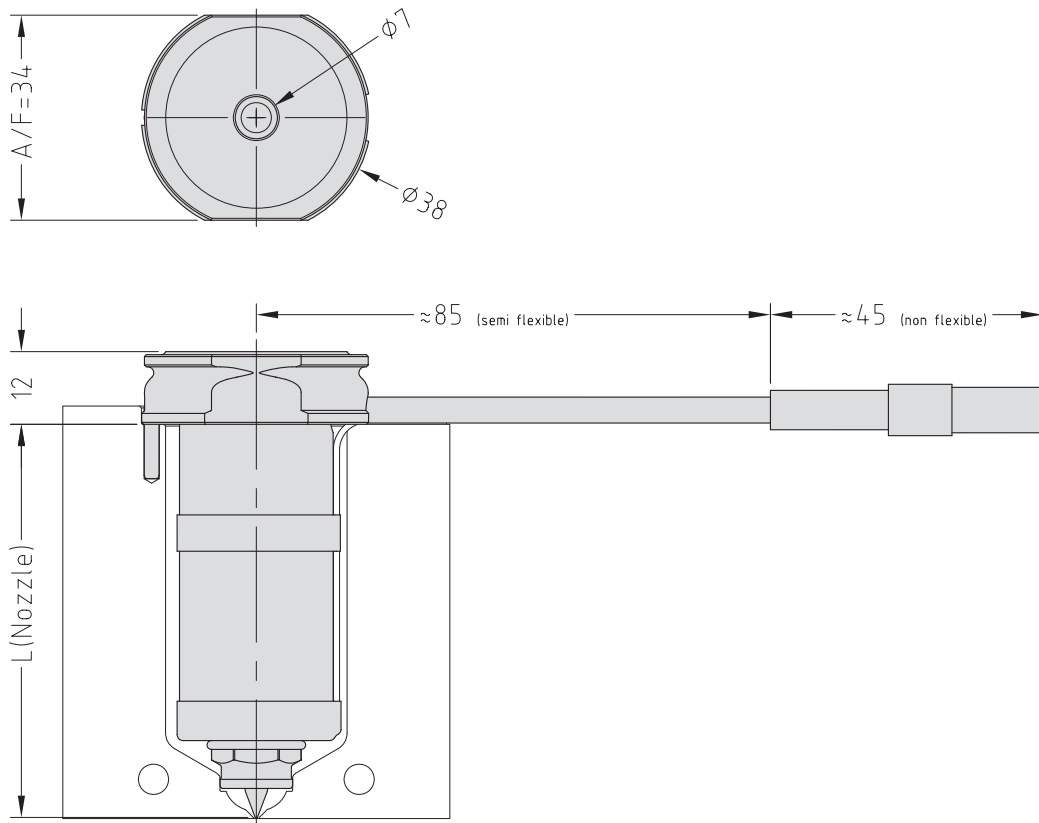
Nozzle Dimensions

Multi-hole Torpedo Tip Nozzle Code	One-hole Torpedo Tip Nozzle Code	Open Tip Nozzle Code	L	$E @ \Delta T = 200C$	$E @ \Delta T = 250C$
BXTT16045	BXIT16045	BXOT16045	45	0.12	0.15
BXTT16055	BXIT16055	BXOT16055	55	0.15	0.18
BXTT16065	BXIT16065	BXOT16065	65	0.17	0.21
BXTT16075	BXIT16075	BXOT16075	75	0.20	0.25
BXTT16095	BXIT16095	BXOT16095	95	0.25	0.31
BXTT16115	BXIT16115	BXOT16115	115	0.30	0.38
BXTT16145	BXIT16145	BXOT16145	145	0.38	0.48
BXTT16175	BXIT16175	BXOT16175	175	0.46	0.58

Nozzle Fitment and Gate Dimensions

$$E = L \times 0.0000132 \times (\text{nozzle temp. } ^\circ\text{C} - \text{mould temp. } ^\circ\text{C})$$

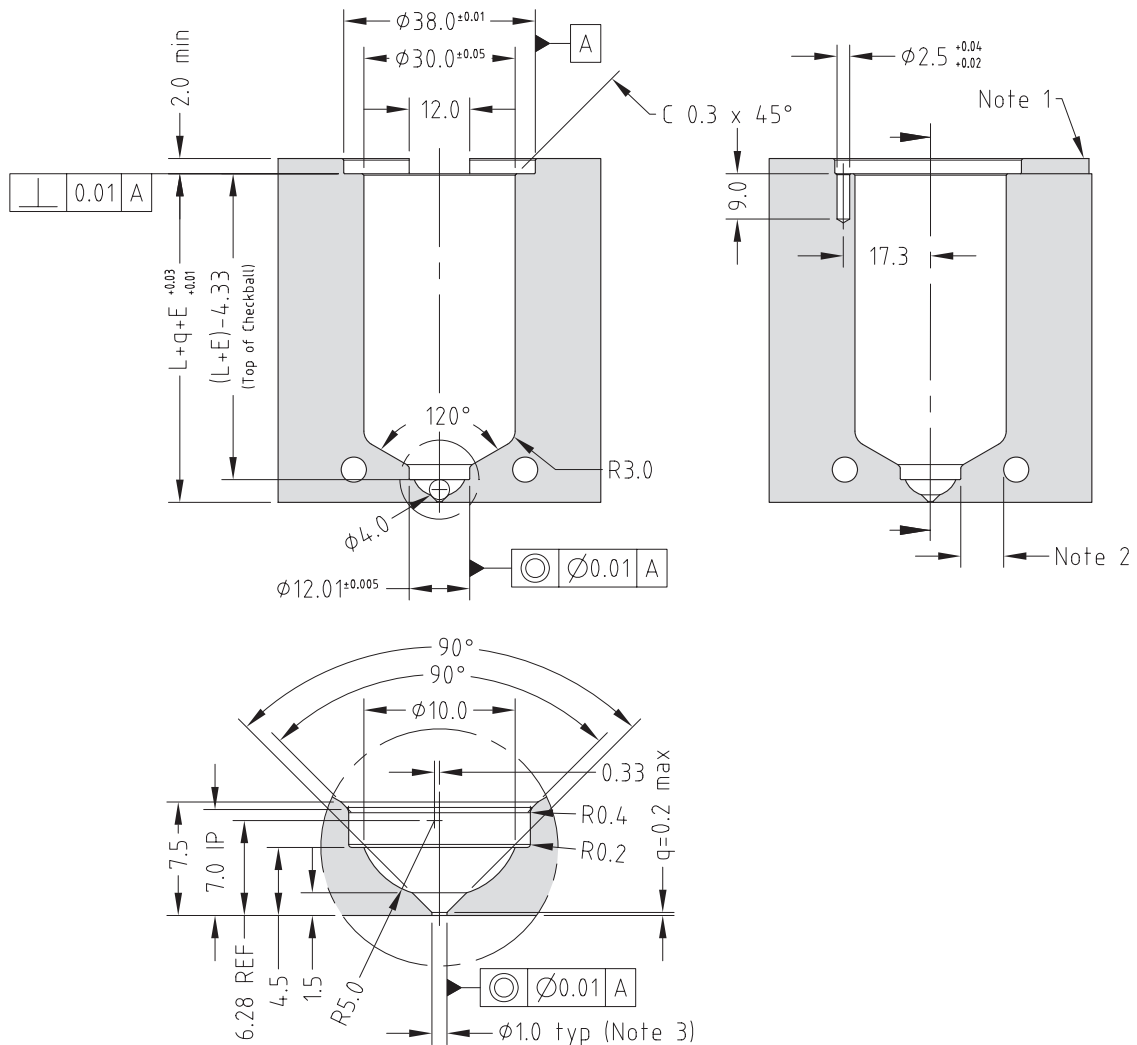

Note

1. Wire channel to suit mould.
 2. Gate cooling is critical for correct operation and gate quality. → See Cooling section in Technical Specifications.
 3. Modify gate diameter and land to suit the part. → See Gate Modifications in Technical Specifications.
- * Minimum strength (σ_y) of nozzle plate 800MPa.

Tip and Material Grade Availability

Tip (Code)	G1	G2	G5
Multi-hole Torpedo Tip (X 16 TT)	✓	✓	✓
One-hole Torpedo Tip (X 16 IT)	✓	✓	✓
Open Tip (X 16 OT)	✓	×	×

- BN - Standard bush nut
- BE - Full-contact bush nut*

The nozzle codes listed to the right are for nozzle assemblies with a standard bush nut. To order a full-contact bush nut, replace the BN in the code with BE.

To order a nozzle assembly:

Provide the Nozzle Code + Grade
(Order example: BXTBN16175 G5)

To order a tip:

Provide the Tip Code + Grade
(Order example: X 16 IT G5)

Nozzle Dimensions

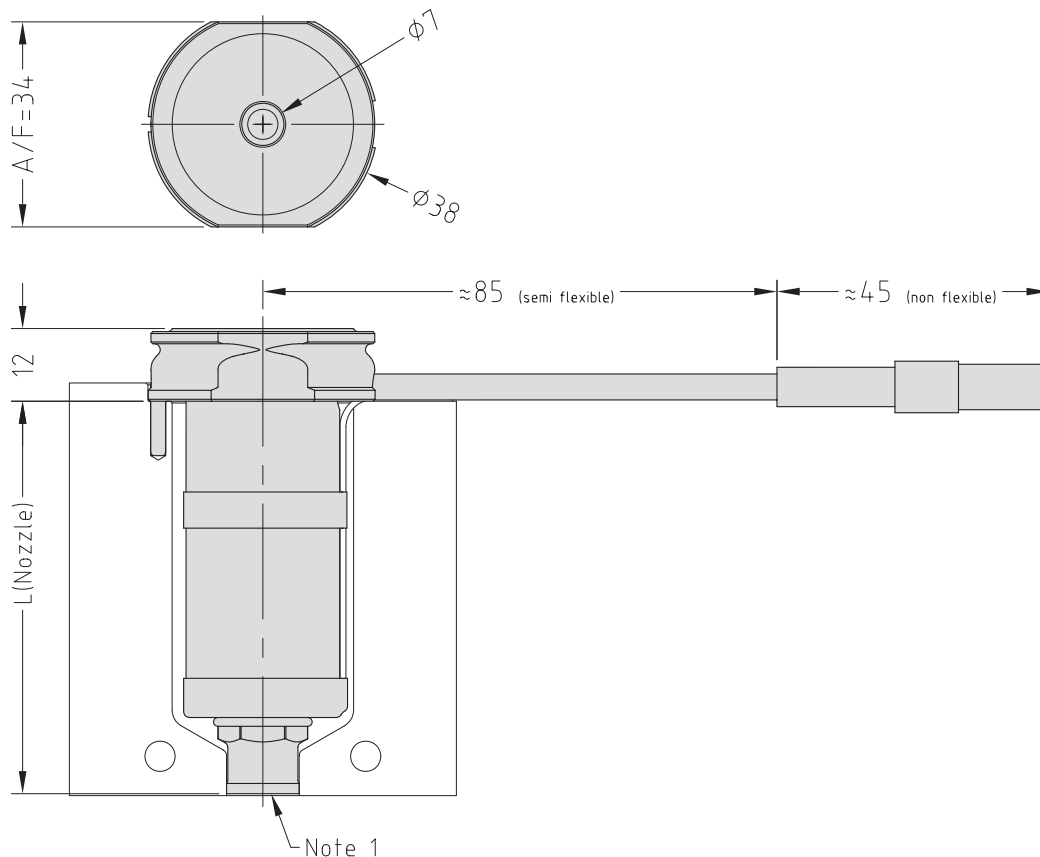
**Note**

1. Modify the contact area to suit the application.

→ See Gate Modifications and Cooling sections in the Technical Specifications.

Multi-hole Torpedo Tip Nozzle Code	One-hole Torpedo Tip Nozzle Code	Open Tip Nozzle Code	L	E ₀ ΔT =200C	E ₀ ΔT =250C
BXTBN16045	BXIBN16045	BXOBN16045	45.2	0.12	0.15
BXTBN16055	BXIBN16055	BXOBN16055	55.2	0.15	0.18
BXTBN16065	BXIBN16065	BXOBN16065	65.2	0.17	0.22
BXTBN16075	BXIBN16075	BXOBN16075	75.2	0.20	0.25
BXTBN16095	BXIBN16095	BXOBN16095	95.2	0.25	0.31
BXTBN16115	BXIBN16115	BXOBN16115	115.2	0.30	0.38
BXTBN16145	BXIBN16145	BXOBN16145	145.2	0.38	0.48
BXTBN16175	BXIBN16175	BXOBN16175	175.2	0.46	0.58

Nozzle Fitment and Gate Dimensions

$$E = L \times 0.0000132 \times (\text{nozzle temp. } ^\circ\text{C} - \text{mould temp. } ^\circ\text{C})$$

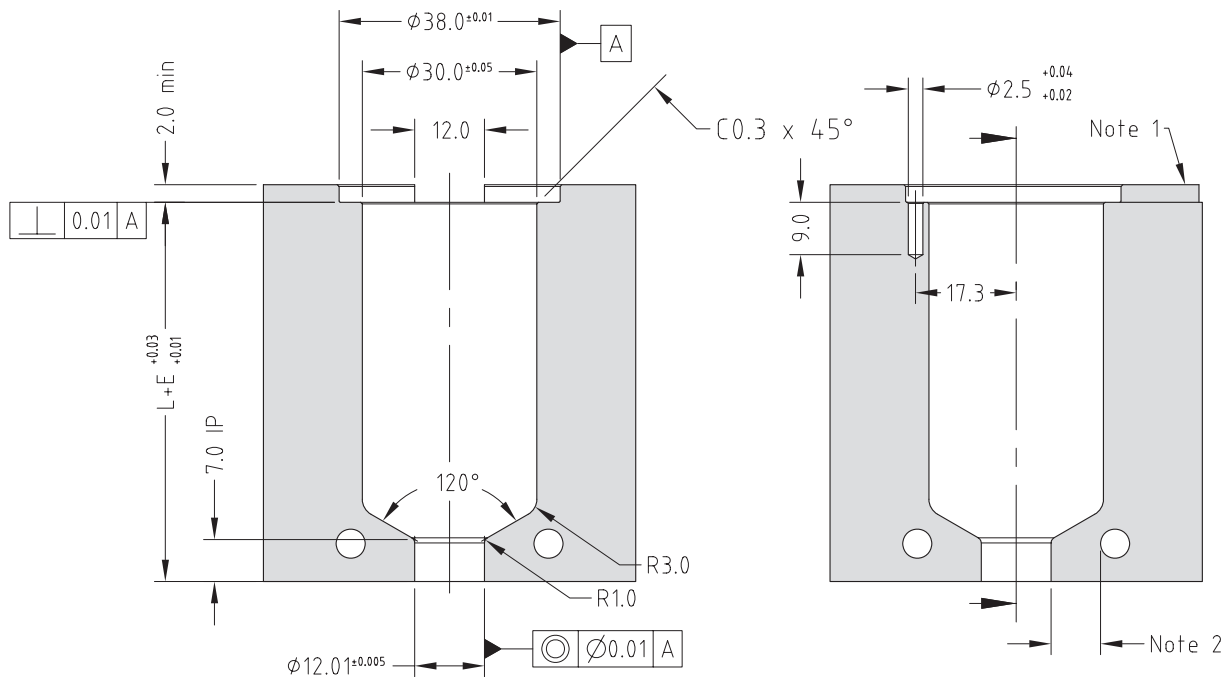

Note

1. Wire channel to suit mould.
 2. Gate cooling is critical for correct operation and gate quality. → See Cooling section in Technical Specifications.
 3. Modify gate diameter and land to suit the part. Supplied with $\emptyset 1.0$ → See Gate Modifications in Technical Specifications.
- * Minimum strength (σ_y) of nozzle plate 800MPa.

Tip and Material Grade Availability

Tip (Code)	G1	G2	G5
Multi-hole Torpedo Tip (X 16 TT)	✓	✓	✓
One-hole Torpedo Tip (X 16 IT)	✓	✓	✓
Open Tip (X 16 OT)	✓	×	×

To order a nozzle assembly:

Provide the Nozzle Code + Grade
(Order example: BXOSN16175 G5)

To order a tip:

Provide the Tip Code + Grade
(Order example: X 16 IT G5)

Nozzle Dimensions

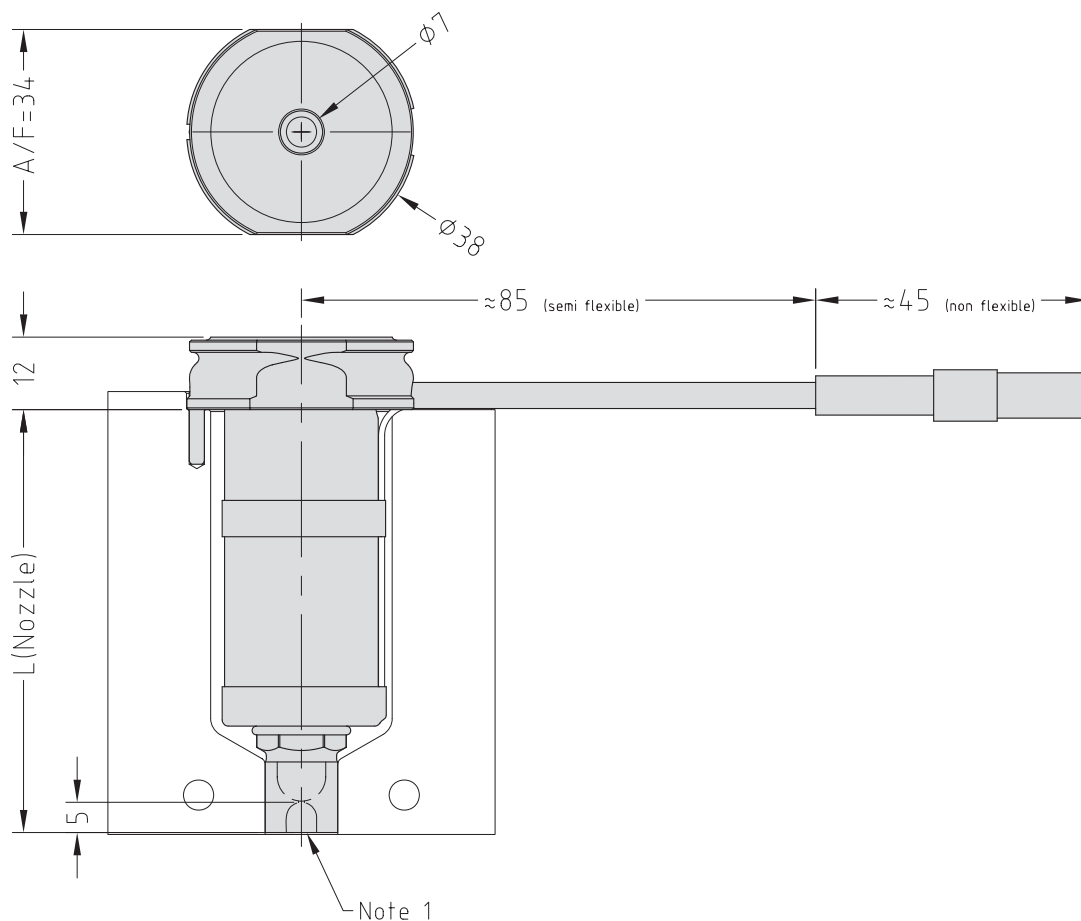
**Note**

1. Modify the contact area and the sprue nut to suit the application.
→ See Gate Modifications and Cooling sections in the Technical Specifications.

Multi-hole Torpedo Tip Nozzle Code	One-hole Torpedo Tip Nozzle Code	Open Tip Nozzle Code	L	$E\Delta T$ =200C	$E\Delta T$ =250C
BXTSN16045	BXISN16045	BXOSN16045	50.2	0.13	0.17
BXTSN16055	BXISN16055	BXOSN16055	60.2	0.16	0.20
BXTSN16065	BXISN16065	BXOSN16065	70.2	0.19	0.23
BXTSN16075	BXISN16075	BXOSN16075	80.2	0.21	0.26
BXTSN16095	BXISN16095	BXOSN16095	100.2	0.26	0.33
BXTSN16115	BXISN16115	BXOSN16115	120.2	0.32	0.40
BXTSN16145	BXISN16145	BXOSN16145	150.2	0.40	0.50
BXTSN16175	BXISN16175	BXOSN16175	180.2	0.48	0.59

Nozzle Fitment and Gate Dimensions

$$E = L \times 0.0000132 \times (\text{nozzle temp. } ^\circ\text{C} - \text{mould temp. } ^\circ\text{C})$$

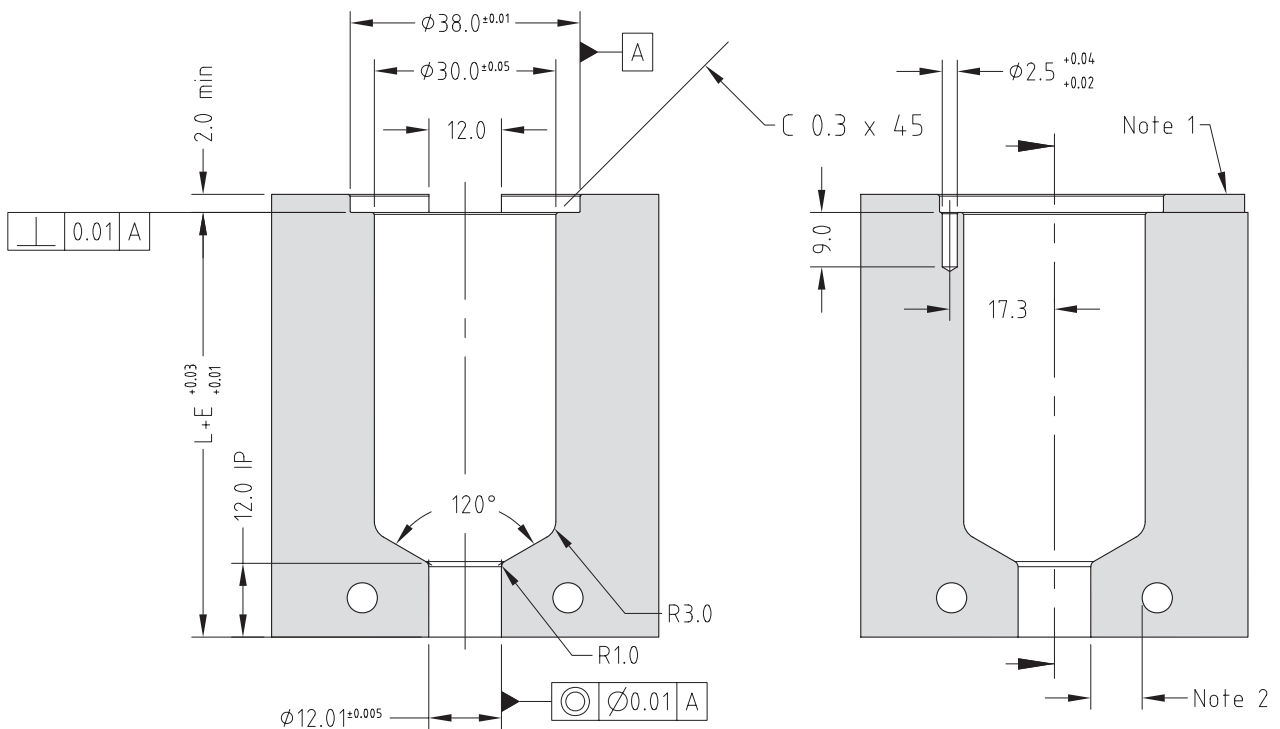

Note

1. Wire channel to suit mould.
 2. Gate cooling is critical for correct operation and gate quality. → See Cooling section in Technical Specifications.
 3. Modify gate diameter and land to suit the part. Supplied with $\varnothing 1.0$ → See Gate Modifications in Technical Specifications.
- * Minimum strength (σ_y) of nozzle plate 800MPa.

Tip and Material Grade Availability

Tip (Code)	G1	G2	G5
Multi-hole Torpedo Tip (X 16 TT)	✓	✓	✓
One-hole Torpedo Tip (X 16 IT)	✓	✓	✓
Open Tip (X 16 OT)	✓	×	×

To order a nozzle assembly:

Provide the Nozzle Code + Grade
(Order example: BXOSX16175 G1)

To order a tip:

Provide the Tip Code + Grade
(Order example: X 16 IT G5)

Nozzle Dimensions

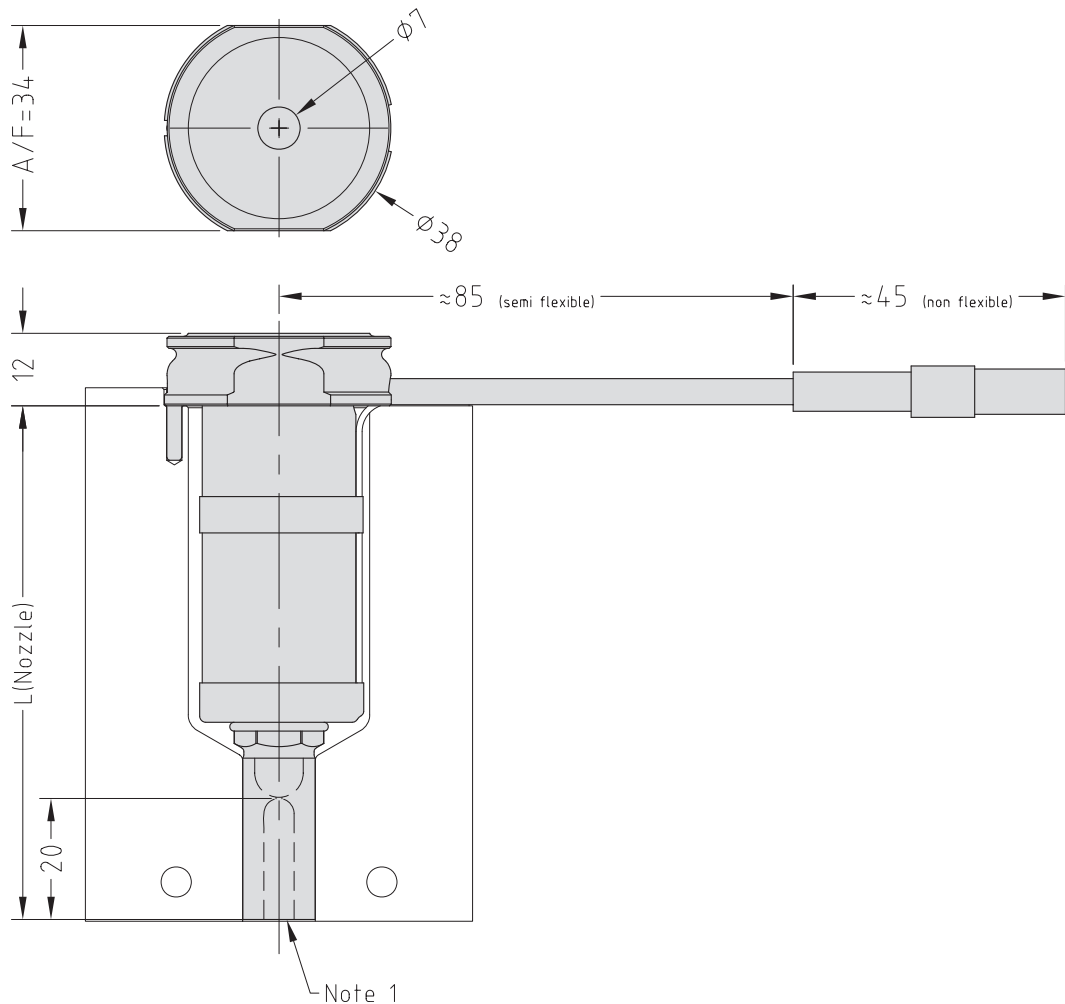
**Note**

1. Modify the contact area and the sprue nut to suit the application.
→ See Gate Modifications and Cooling sections in the Technical Specifications.

Tip and Material Grade Availability

Tip (Code)	G1	G2	G5
Multi-hole Torpedo Tip (X 16 TT)	✓	✓	✓
One-hole Torpedo Tip (X 16 IT)	✓	✓	✓
Open Tip (X 16 OT)	✓	×	×

To order a nozzle assembly:

Provide the Nozzle Code + Grade
(Order example: BXOSL16175 G5)

To order a tip:

Provide the Tip Code + Grade
(Order example: X 16 IT G5)

Nozzle Dimensions

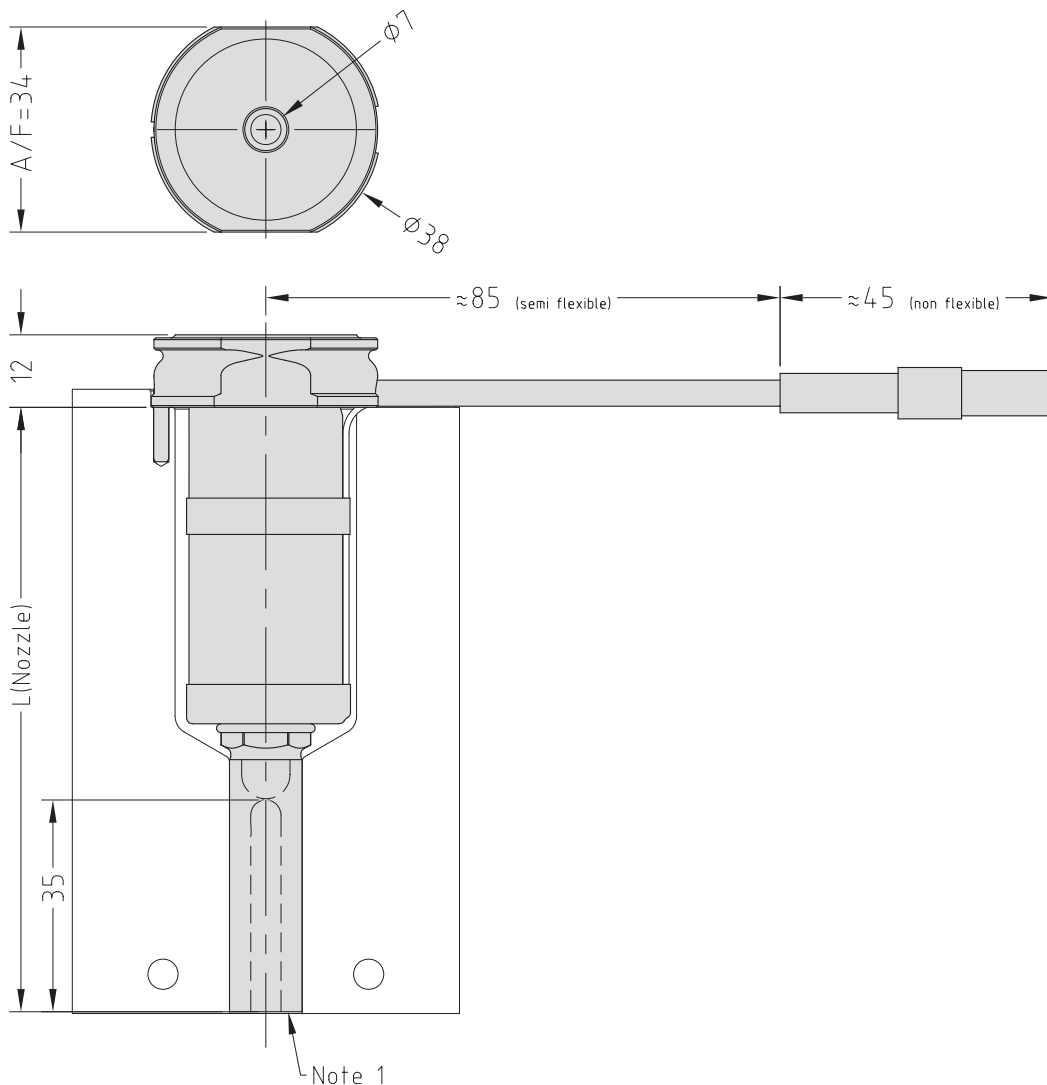
**Note**

1. Modify the contact area and the bush nut to suit the application.
- See Gate Modifications and Cooling sections in the Technical Specifications.

Multi-hole Torpedo Tip Nozzle Code	One-hole Torpedo Tip Nozzle Code	Open Tip Nozzle Code	L	$E\Delta T$ =200C	$E\Delta T$ =250C
BXTSL16045	BXISL16045	BXOSL16045	80.2	0.21	0.26
BXTSL16055	BXISL16055	BXOSL16055	90.2	0.24	0.30
BXTSL16065	BXISL16065	BXOSL16065	100.2	0.26	0.33
BXTSL16075	BXISL16075	BXOSL16075	110.2	0.29	0.36
BXTSL16095	BXISL16095	BXOSL16095	130.2	0.34	0.43
BXTSL16115	BXISL16115	BXOSL16115	150.2	0.40	0.50
BXTSL16145	BXISL16145	BXOSL16145	180.2	0.48	0.59
BXTSL16175	BXISL16175	BXOSL16175	210.2	0.55	0.69

Nozzle Fitment and Gate Dimensions

$$E = L \times 0.0000132 \times (\text{nozzle temp. } ^\circ\text{C} - \text{mould temp. } ^\circ\text{C})$$

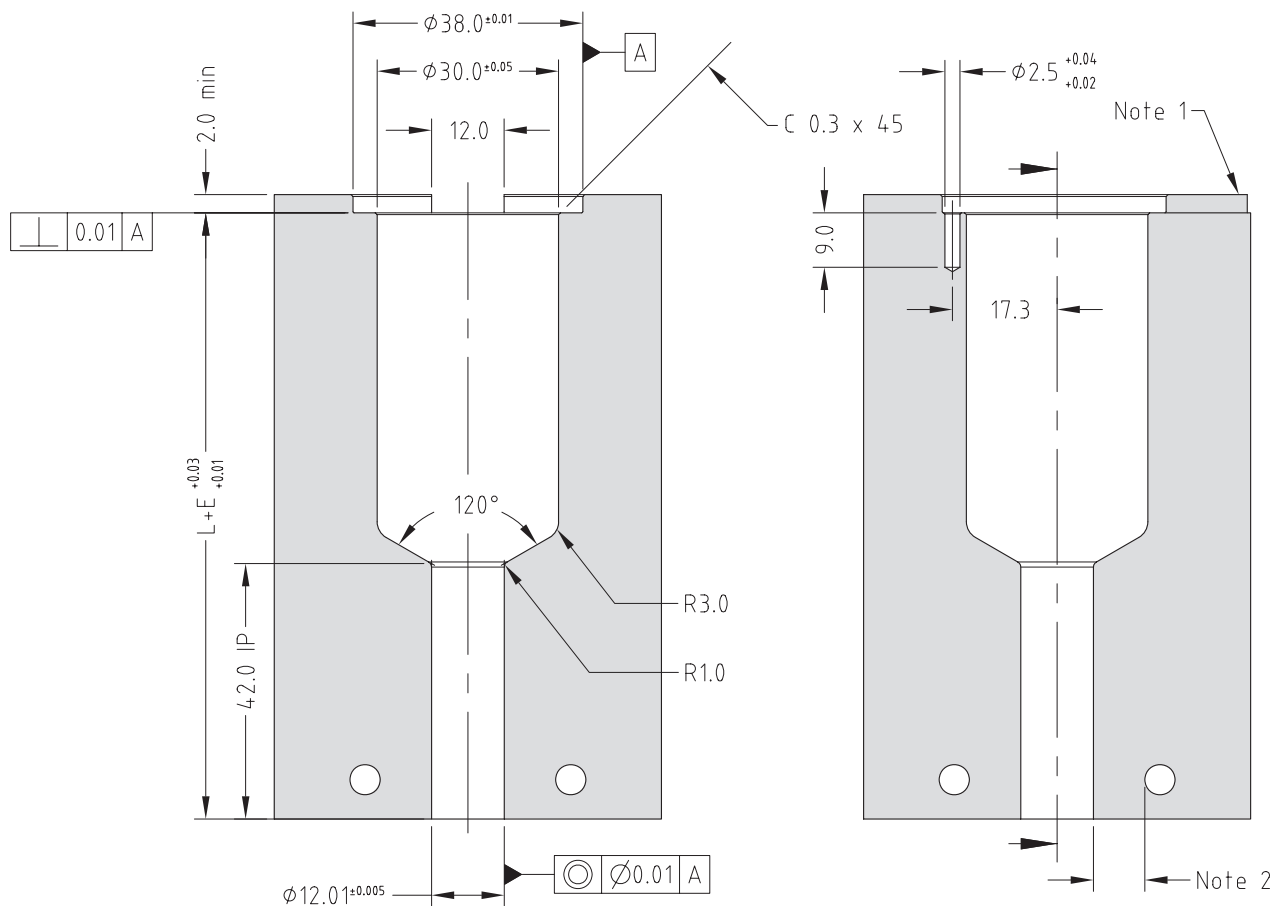

Note

1. Wire channel to suit mould.
 2. Gate cooling is critical for correct operation and gate quality. → See Cooling section in Technical Specifications.
 3. Modify gate diameter and land to suit the part. Supplied with $\varnothing 1.0$ → See Gate Modifications in Technical Specifications.
- * Minimum strength (σ_y) of nozzle plate 800MPa.

Tip and Material Grade Availability

Tip (Code)	G1	G2	G5
Multi-hole Torpedo Tip (X 16 TT+5)	✓	✓	✗
One-hole Torpedo Tip (X 16 IT+5)	✓	✓	✗
Open Tip	✗	✗	✗

To order a nozzle assembly:

Provide the Nozzle Code + Grade
(Order example: BXTT16175+5 G1)

To order a tip:

Provide the Tip Code + Grade
(Order example: X 16 IT+5 G1)

Nozzle Dimensions

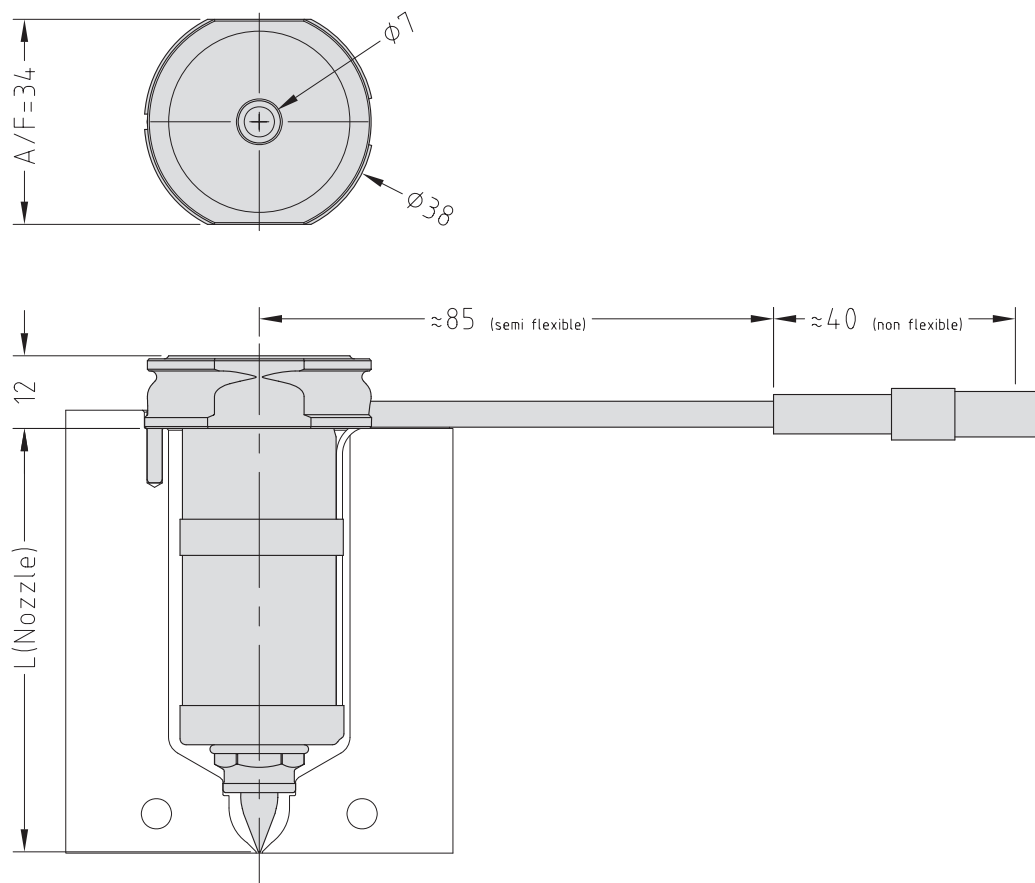

Multi-hole Torpedo Tip Nozzle Code	One-hole Torpedo Tip Nozzle Code	L	$E @ \Delta T = 200C$	$E @ \Delta T = 250C$
BXTT16045+5	BXIT16045+5	50	0.13	0.17
BXTT16055+5	BXIT16055+5	60	0.16	0.20
BXTT16065+5	BXIT16065+5	70	0.18	0.23
BXTT16075+5	BXIT16075+5	80	0.21	0.26
BXTT16095+5	BXIT16095+5	100	0.26	0.33
BXTT16115+5	BXIT16115+5	120	0.32	0.40
BXTT16145+5	BXIT16145+5	150	0.40	0.50
BXTT16175+5	BXIT16175+5	180	0.48	0.59

Nozzle Fitment and Gate Dimensions

$$E = L \times 0.0000132 \times (\text{nozzle temp. } ^\circ\text{C} - \text{mould temp. } ^\circ\text{C})$$

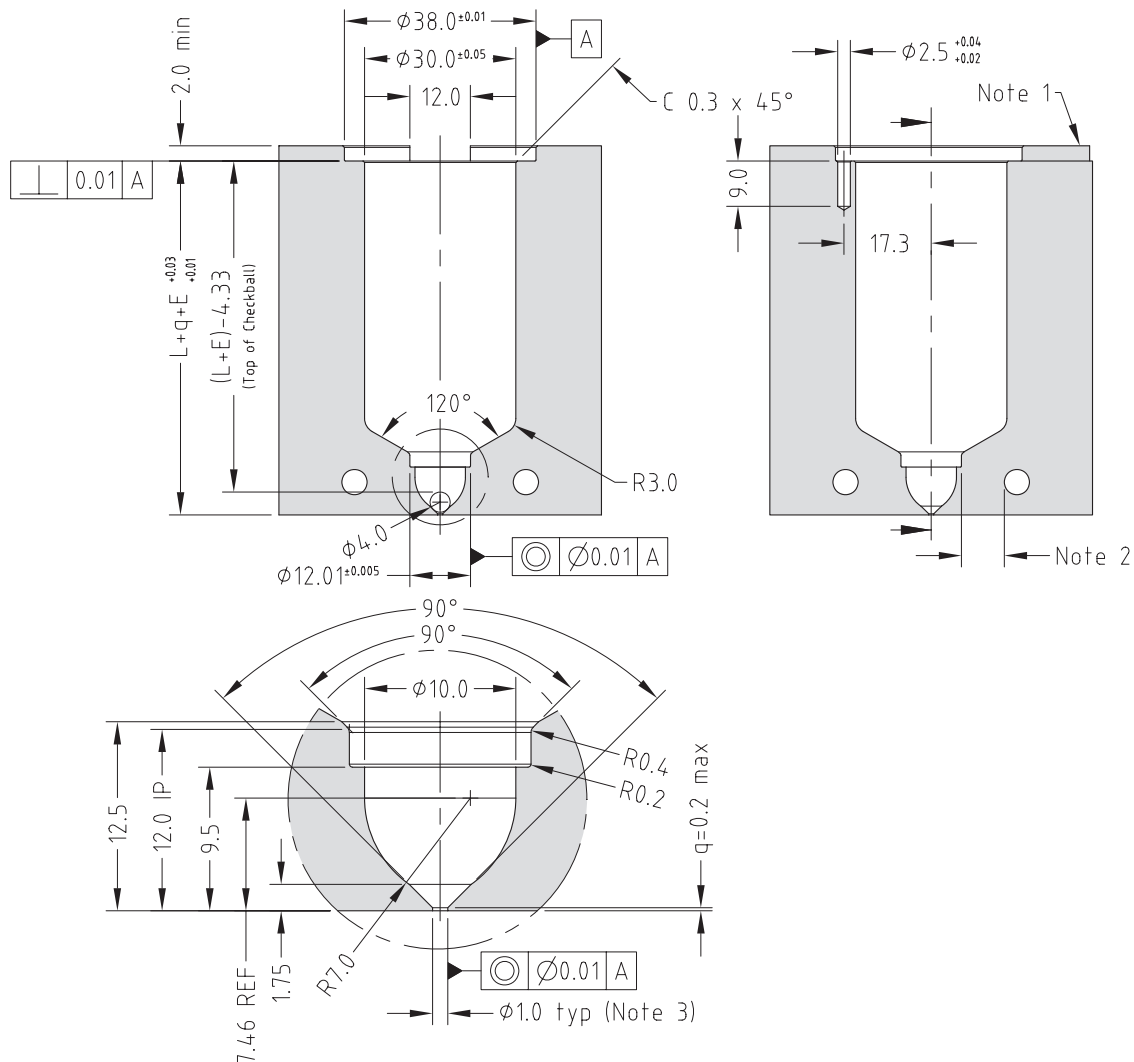

Note

1. Wire channel to suit mould.
 2. Gate cooling is critical for correct operation and gate quality. → See Cooling section in Technical Specifications.
 3. Modify gate diameter and land to suit the part. → See Gate Modifications in Technical Specifications.
- * Minimum strength (σ_y) of nozzle plate 800MPa.

Tip and Material Grade Availability

Tip (Code)	G1	G2	G5
Multi-hole Torpedo Tip (X 16 TT+10)	✓	✓	✗
One-hole Torpedo Tip (X 16 IT+10)	✓	✓	✗
Open Tip	✗	✗	✗

To order a nozzle assembly:

Provide the Nozzle Code + Grade
(Order example: BXTT16175+10 G1)

To order a tip:

Provide the Tip Code + Grade
(Order example: X 16 IT+10 G1)

Nozzle Dimensions

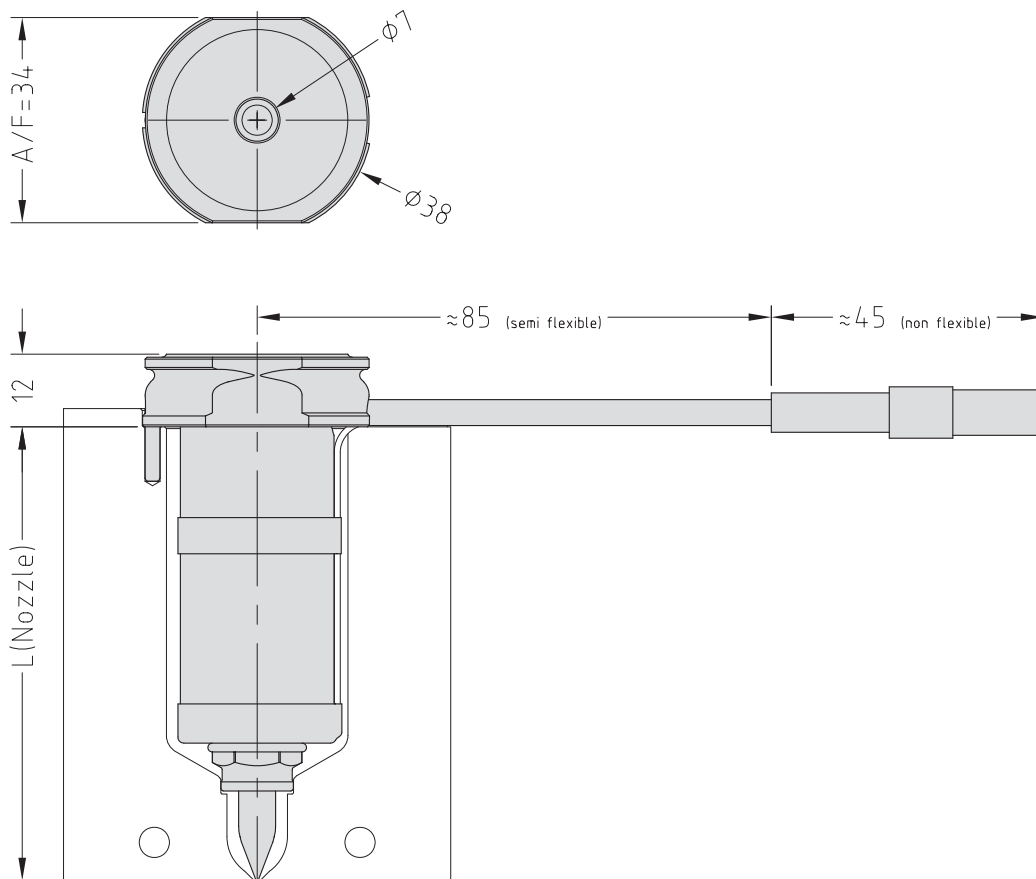

Multi-hole Torpedo Tip Nozzle Code	One-hole Torpedo Tip Nozzle Code	L	E@ΔT =200C	E@ΔT =250C
BXTT16045+10	BXIT16045+10	55	0.15	0.18
BXTT16055+10	BXIT16055+10	65	0.17	0.21
BXTT16065+10	BXIT16065+10	75	0.20	0.25
BXTT16075+10	BXIT16075+10	85	0.22	0.28
BXTT16095+10	BXIT16095+10	105	0.28	0.35
BXTT16115+10	BXIT16115+10	125	0.33	0.41
BXTT16145+10	BXIT16145+10	155	0.41	0.51
BXTT16175+10	BXIT16175+10	185	0.49	0.61

Nozzle Fitment and Gate Dimensions

$$E = L \times 0.0000132 \times (\text{nozzle temp. } ^\circ\text{C} - \text{mould temp. } ^\circ\text{C})$$

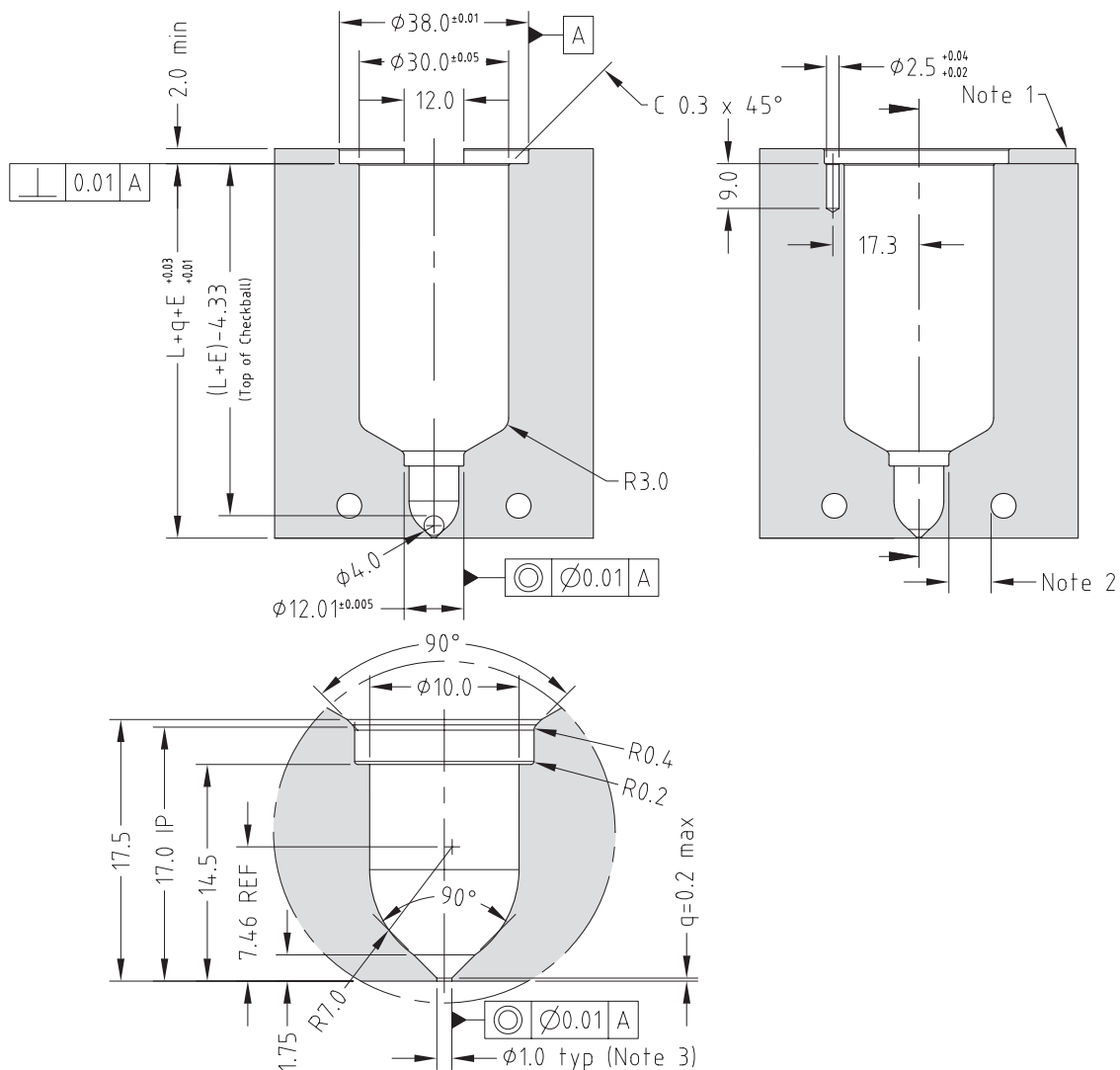

Note

1. Wire channel to suit mould.
 2. Gate cooling is critical for correct operation and gate quality. → See Cooling section in Technical Specifications.
 3. Modify gate diameter and land to suit the part. → See Gate Modifications in Technical Specifications.
- * Minimum strength (σ_y) of nozzle plate 800MPa.

Mastip Head Office New Zealand

558 Rosebank Road
Avondale 1026, Auckland
PO Box 90-651
Victoria Street West
Auckland 1142
New Zealand
Phone: +64 9 970 2100
Fax: +64 9 970 2070
Email: mastip@mastip.com

Mastip Regional Office Europe

Phone: +33 4 724 72 800
Fax: +33 4 724 72 801
Email: europe@mastip.com

Mastip Regional Office China

Phone: +86 21 644 77838
Fax: +86 21 644 77828
Email: china@mastip.com

Mastip Regional Office North America

Phone: +1 262 644 9400
Fax: +1 262 644 9402
Email: northamerica@mastip.com

40-000-010 V1.03



BXTG19



smart hot runner solutions

www.mastip.com

Tip and Material Grade Availability

Tip (Code)	G1	G2	G5
Multi-hole Torpedo Tip (X 19 TT)	✓	✓	✓
One-hole Torpedo Tip (X 19 IT)	✓	✓	✓
Open Tip (X 19 OT)	✓	×	✓

To order a nozzle assembly:

Provide the Nozzle Code + Grade
(Order example: BXIT19175 G2)

To order a tip:

Provide the Tip Code + Grade
(Order example: X 19 OT G5)

Nozzle Dimensions

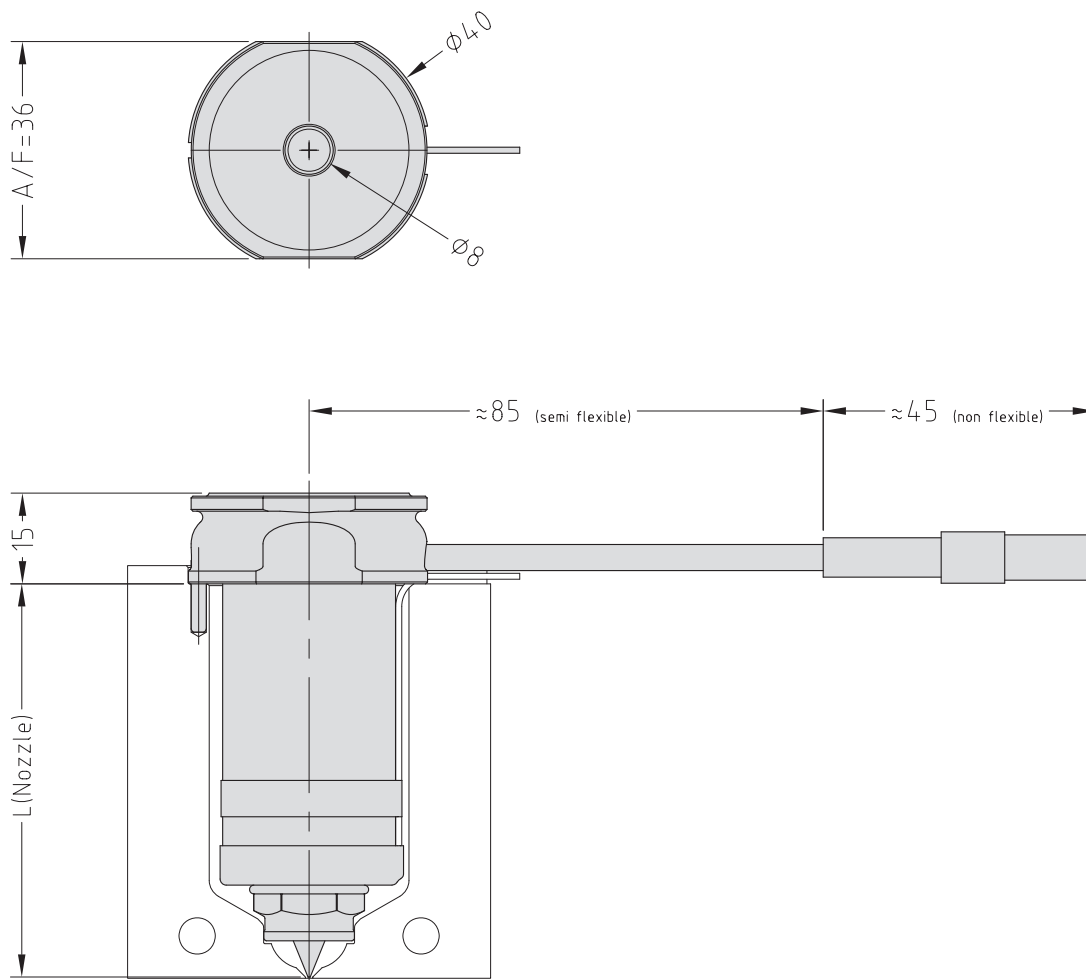

Multi-hole Torpedo Tip Nozzle Code	One-hole Torpedo Tip Nozzle Code	Open Tip Nozzle Code	L	$E@ΔT = 200C$	$E@ΔT = 250C$
BXTT19055	BXIT19055	BXOT19055	55	0.15	0.18
BXTT19065	BXIT19065	BXOT19065	65	0.17	0.21
BXTT19075	BXIT19075	BXOT19075	75	0.20	0.25
BXTT19095	BXIT19095	BXOT19095	95	0.25	0.31
BXTT19115	BXIT19115	BXOT19115	115	0.30	0.38
BXTT19145	BXIT19145	BXOT19145	145	0.38	0.48
BXTT19175	BXIT19175	BXOT19175	175	0.46	0.58

Nozzle Fitment and Gate Dimensions

$E = L \times 0.0000132 \times (\text{nozzle temp. } ^\circ C - \text{mould temp. } ^\circ C)$

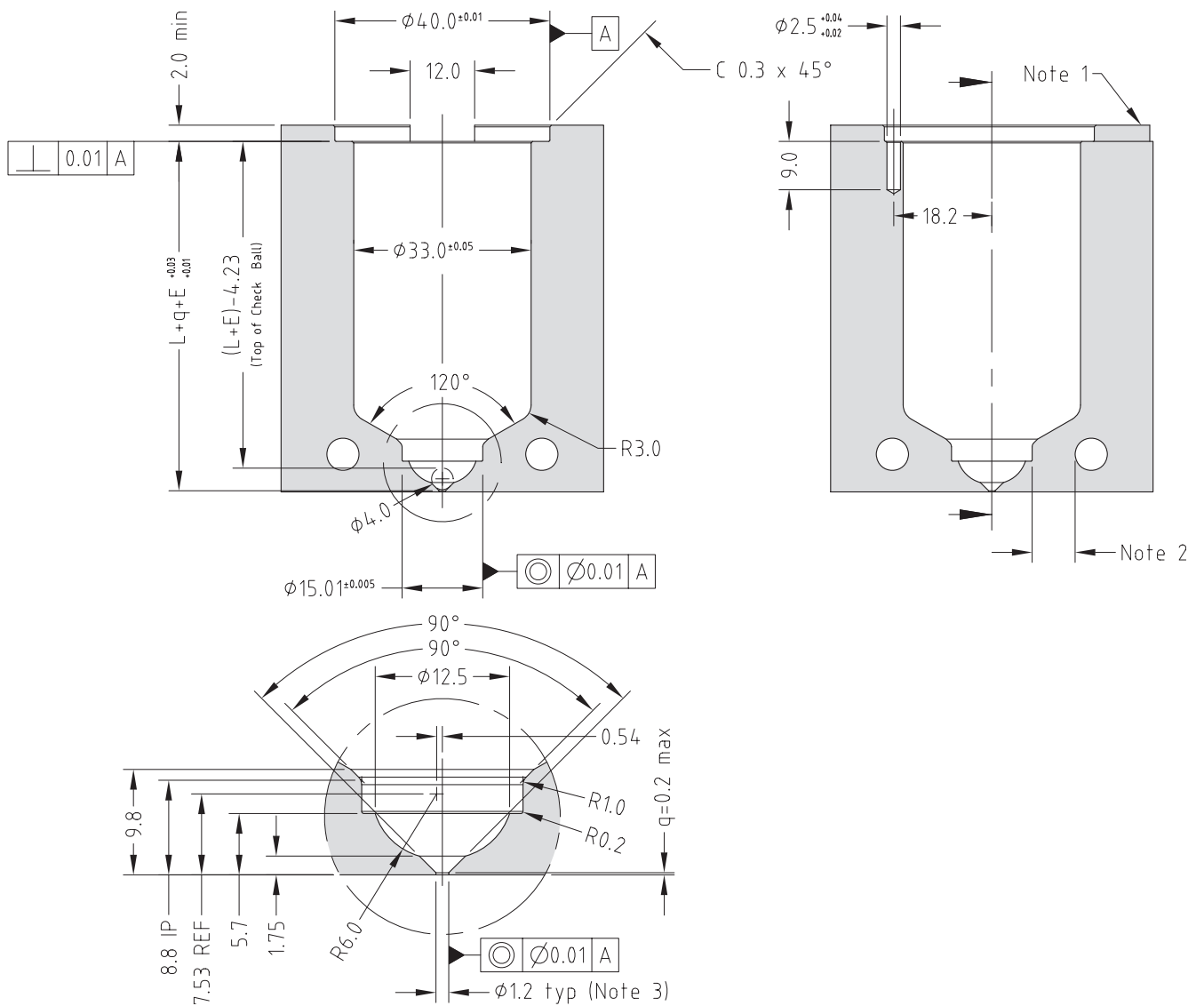

Note

- Wire channel to suit mould.
 - Gate cooling is critical for correct operation and gate quality. → See Cooling section in Technical Specifications.
 - Modify gate diameter and land to suit the part. → See Gate Modifications in Technical Specifications.
- * Minimum strength (σ_y) of nozzle plate 800MPa.

Tip and Material Grade Availability

Tip (Code)	G1	G2	G5
Multi-hole Torpedo Tip (X 19 TT)	✓	✓	✓
One-hole Torpedo Tip (X 19 IT)	✓	✓	✓
Open Tip (X 19 OT)	✓	×	✓

Bush Nut Options

- BN - Standard bush nut
- BE - Full-contact bush nut*

The nozzle codes listed to the right are for nozzle assemblies with a standard bush nut. To order a full-contact bush nut, replace the BN in the code with BE.

To order a nozzle assembly:

Provide the Nozzle Code + Grade
(Order example: BXIBN19175 G5)

To order a tip:

Provide the Tip Code + Grade
(Order example: X 19 IT G5)

Nozzle Dimensions

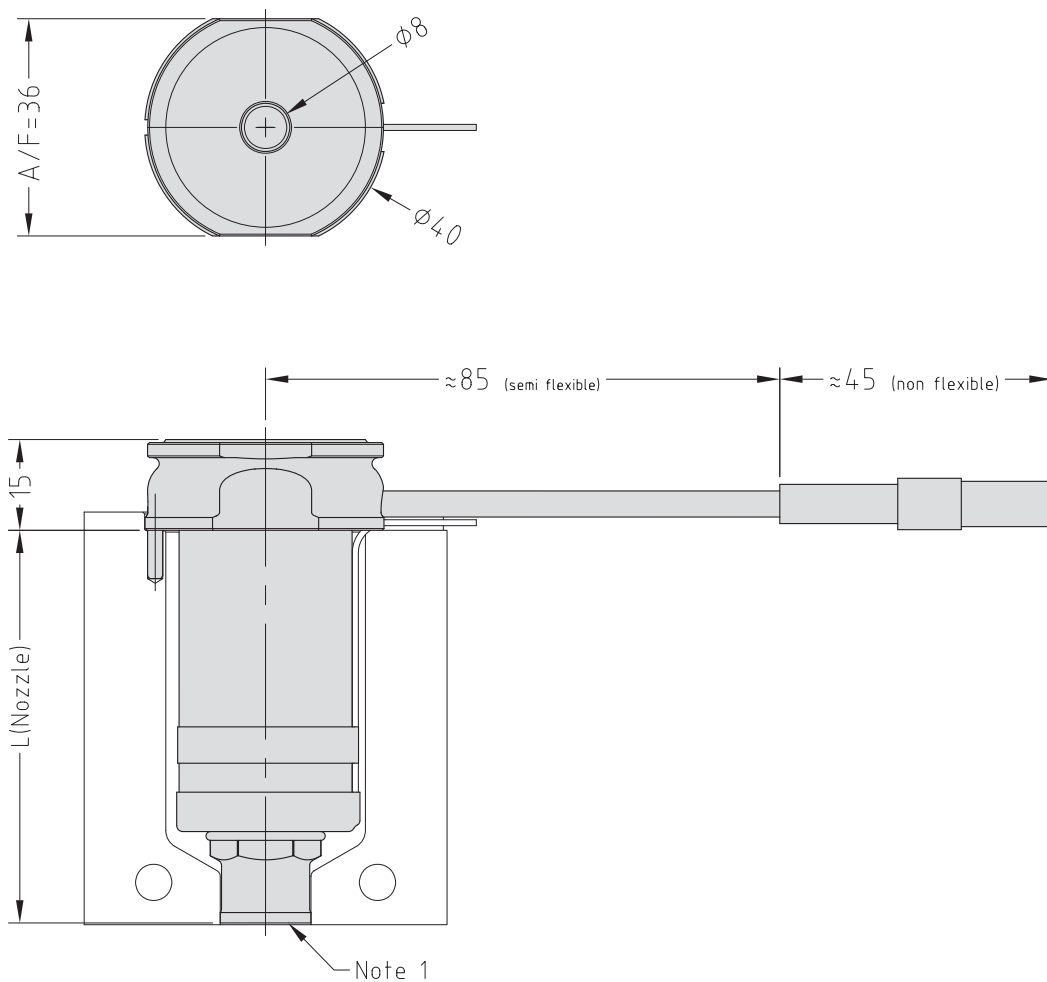
**Note**

1. Modify the contact area to suit the application.

→ See Gate Modifications and Cooling sections in the Technical Specifications.

Multi-hole Torpedo Tip Nozzle Code	One-hole Torpedo Tip Nozzle Code	Open Tip Nozzle Code	L	$E @ \Delta T = 200C$	$E @ \Delta T = 250C$
BXTBN19055	BXIBN19055	BXOBN19055	55.2	0.15	0.18
BXTBN19065	BXIBN19065	BXOBN19065	65.2	0.17	0.22
BXTBN19075	BXIBN19075	BXOBN19075	75.2	0.20	0.25
BXTBN19095	BXIBN19095	BXOBN19095	95.2	0.25	0.31
BXTBN19115	BXIBN19115	BXOBN19115	115.2	0.30	0.38
BXTBN19145	BXIBN19145	BXOBN19145	145.2	0.38	0.48
BXTBN19175	BXIBN19175	BXOBN19175	175.2	0.46	0.58

Nozzle Fitment and Gate Dimensions

$$E = L \times 0.0000132 \times (\text{nozzle temp. } ^\circ\text{C} - \text{mould temp. } ^\circ\text{C})$$

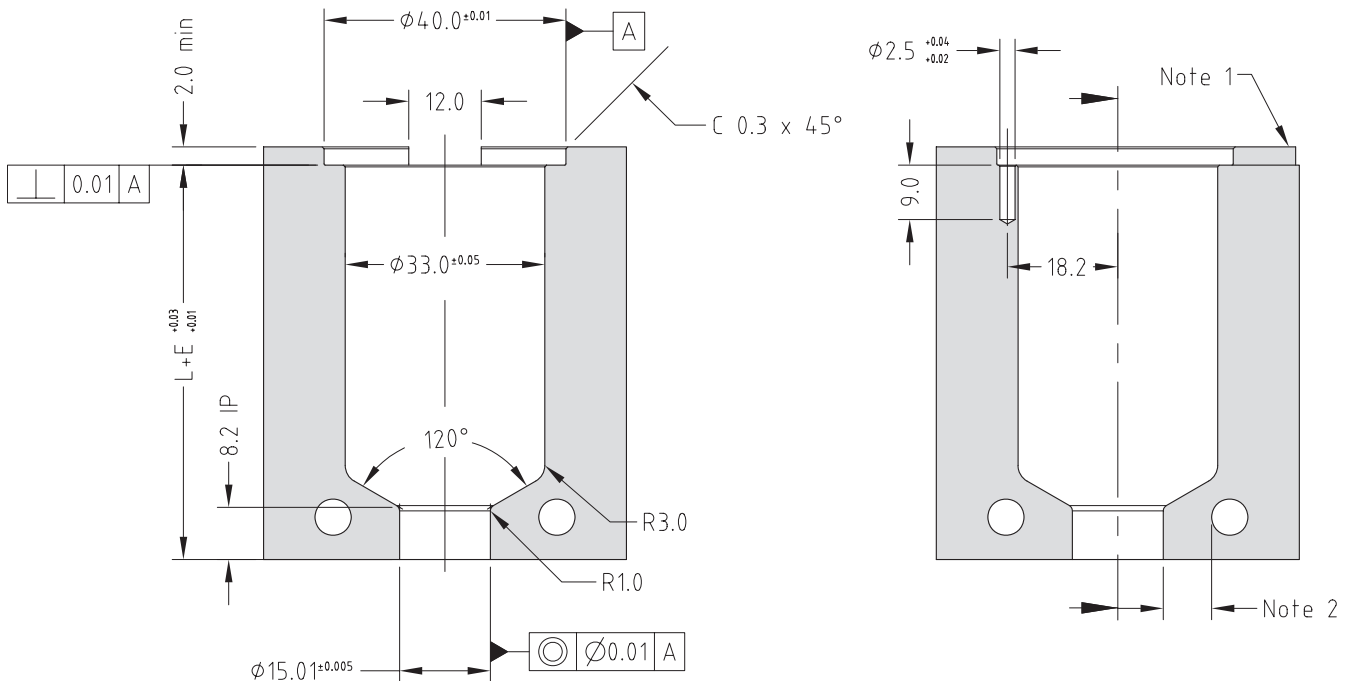

Note

1. Wire channel to suit mould.
 2. Gate cooling is critical for correct operation and gate quality. → See Cooling section in Technical Specifications.
 3. Modify gate diameter and land to suit the part. Supplied with $\varnothing 1.2$ → See Gate Modifications in Technical Specifications.
- * Minimum strength (σ_y) of nozzle plate 800MPa.

Tip and Material Grade Availability

Tip (Code)	G1	G2	G5
Multi-hole Torpedo Tip (X 19 TT)	✓	✓	✓
One-hole Torpedo Tip (X 19 IT)	✓	✓	✓
Open Tip (X 19 OT)	✓	×	✓

To order a nozzle assembly:

Provide the Nozzle Code + Grade
(Order example: BXISN19175 G5)

To order a tip:

Provide the Tip Code + Grade
(Order example: X 19 IT G5)

Nozzle Dimensions

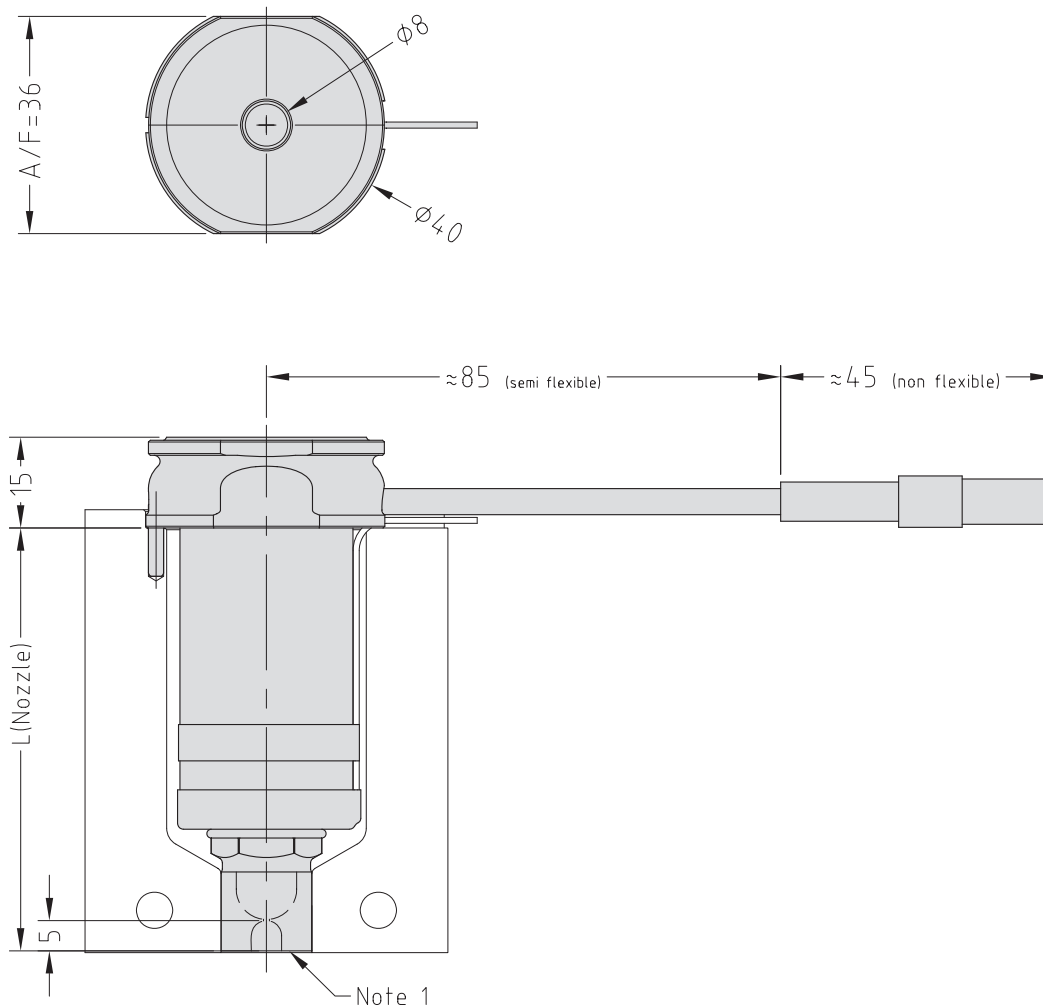
**Note**

1. Modify the contact area and the sprue nut to suit the application.

→ See Gate Modifications and Cooling sections in the Technical Specifications.

Multi-hole Torpedo Tip Nozzle Code	One-hole Torpedo Tip Nozzle Code	Open Tip Nozzle Code	L	$E\Delta T$ =200C	$E\Delta T$ =250C
BXTSN19055	BXISN19055	BXOSN19055	60.2	0.16	0.20
BXTSN19065	BXISN19065	BXOSN19065	70.2	0.19	0.23
BXTSN19075	BXISN19075	BXOSN19075	80.2	0.21	0.26
BXTSN19095	BXISN19095	BXOSN19095	100.2	0.26	0.33
BXTSN19115	BXISN19115	BXOSN19115	120.2	0.32	0.40
BXTSN19145	BXISN19145	BXOSN19145	150.2	0.40	0.50
BXTSN19175	BXISN19175	BXOSN19175	180.2	0.48	0.59

Nozzle Fitment and Gate Dimensions

$$E = L \times 0.0000132 \times (\text{nozzle temp. } ^\circ\text{C} - \text{mould temp. } ^\circ\text{C})$$

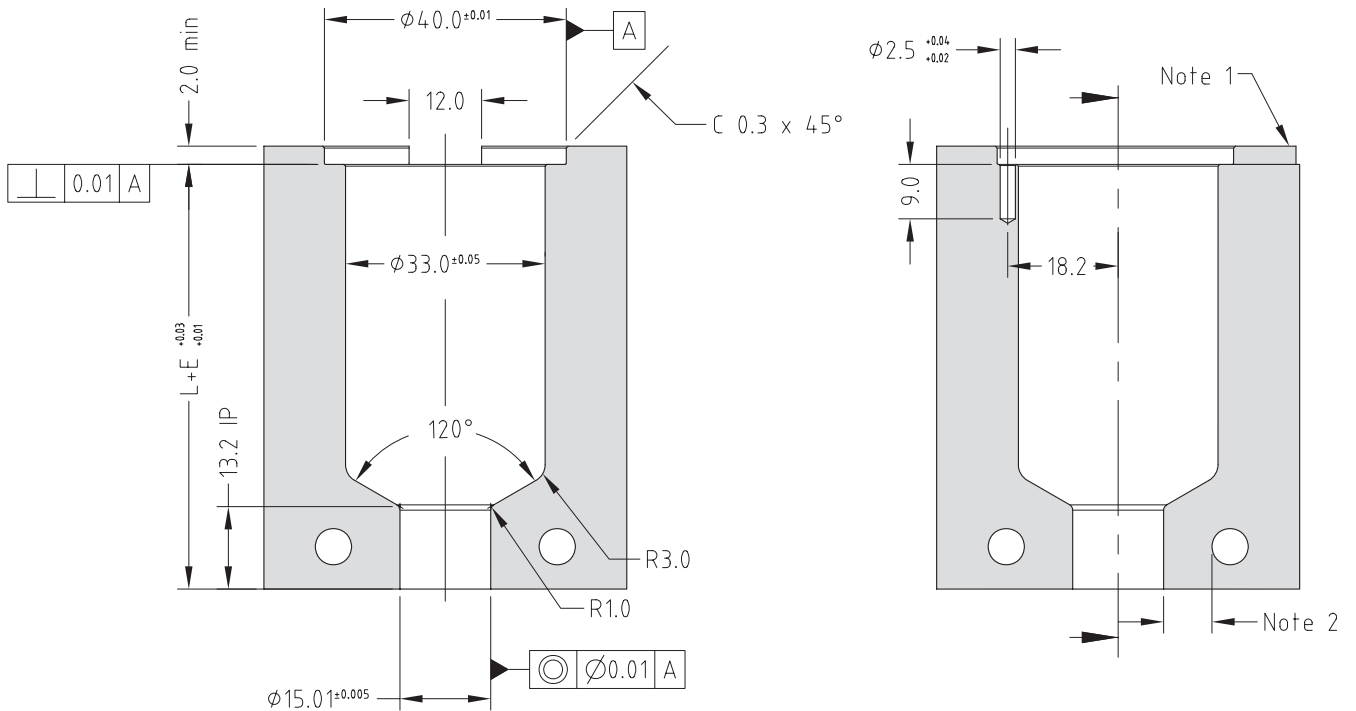

Note

1. Wire channel to suit mould.
 2. Gate cooling is critical for correct operation and gate quality. → See Cooling section in Technical Specifications.
 3. Modify gate diameter and land to suit the part. Supplied with $\emptyset 1.2$ → See Gate Modifications in Technical Specifications.
- * Minimum strength (σ_y) of nozzle plate 800MPa.

Tip and Material Grade Availability

Tip (Code)	G1	G2	G5
Multi-hole Torpedo Tip (X 19 TT)	✓	✓	✓
One-hole Torpedo Tip (X 19 IT)	✓	✓	✓
Open Tip (X 19 OT)	✓	×	✓

To order a nozzle assembly:

Provide the Nozzle Code + Grade
(Order example: BXISX19175 G5)

To order a tip:

Provide the Tip Code + Grade
(Order example: X 19 IT G5)

Nozzle Dimensions

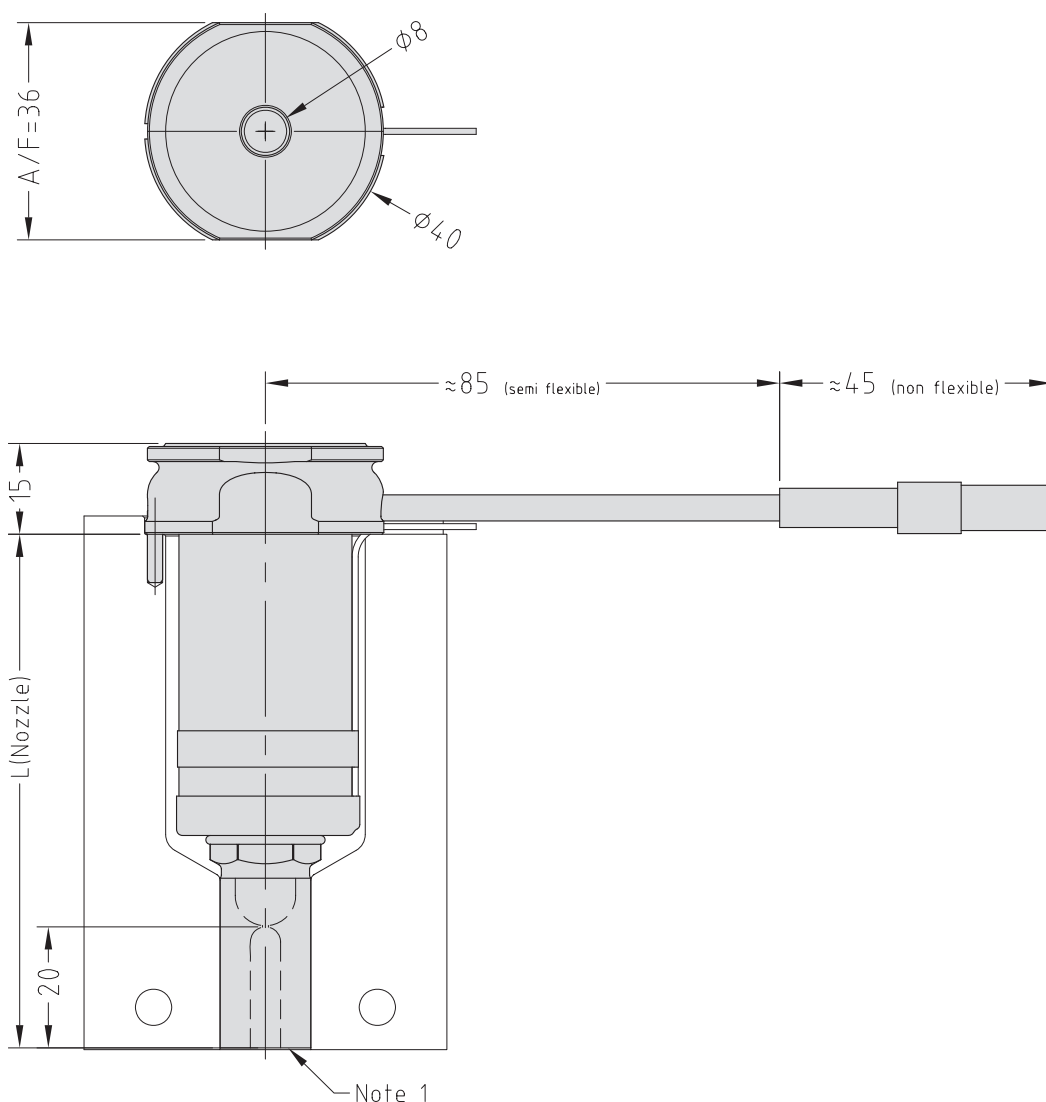
**Note**

1. Modify the contact area and the sprue nut to suit the application.

→ See Gate Modifications and Cooling sections in the Technical Specifications.

Multi-hole Torpedo Tip Nozzle Code	One-hole Torpedo Tip Nozzle Code	Open Tip Nozzle Code	L	$E\Delta T$ =200C	$E\Delta T$ =250C
BXTSX19055	BXISX19055	BXOSX19055	75.2	0.20	0.25
BXTSX19065	BXISX19065	BXOSX19065	85.2	0.23	0.28
BXTSX19075	BXISX19075	BXOSX19075	95.2	0.25	0.31
BXTSX19095	BXISX19095	BXOSX19095	115.2	0.30	0.38
BXTSX19115	BXISX19115	BXOSX19115	135.2	0.36	0.45
BXTSX19145	BXISX19145	BXOSX19145	165.2	0.44	0.55
BXTSX19175	BXISX19175	BXOSX19175	195.2	0.52	0.64

Nozzle Fitment and Gate Dimensions

$$E = L \times 0.0000132 \times (\text{nozzle temp. } ^\circ\text{C} - \text{mould temp. } ^\circ\text{C})$$

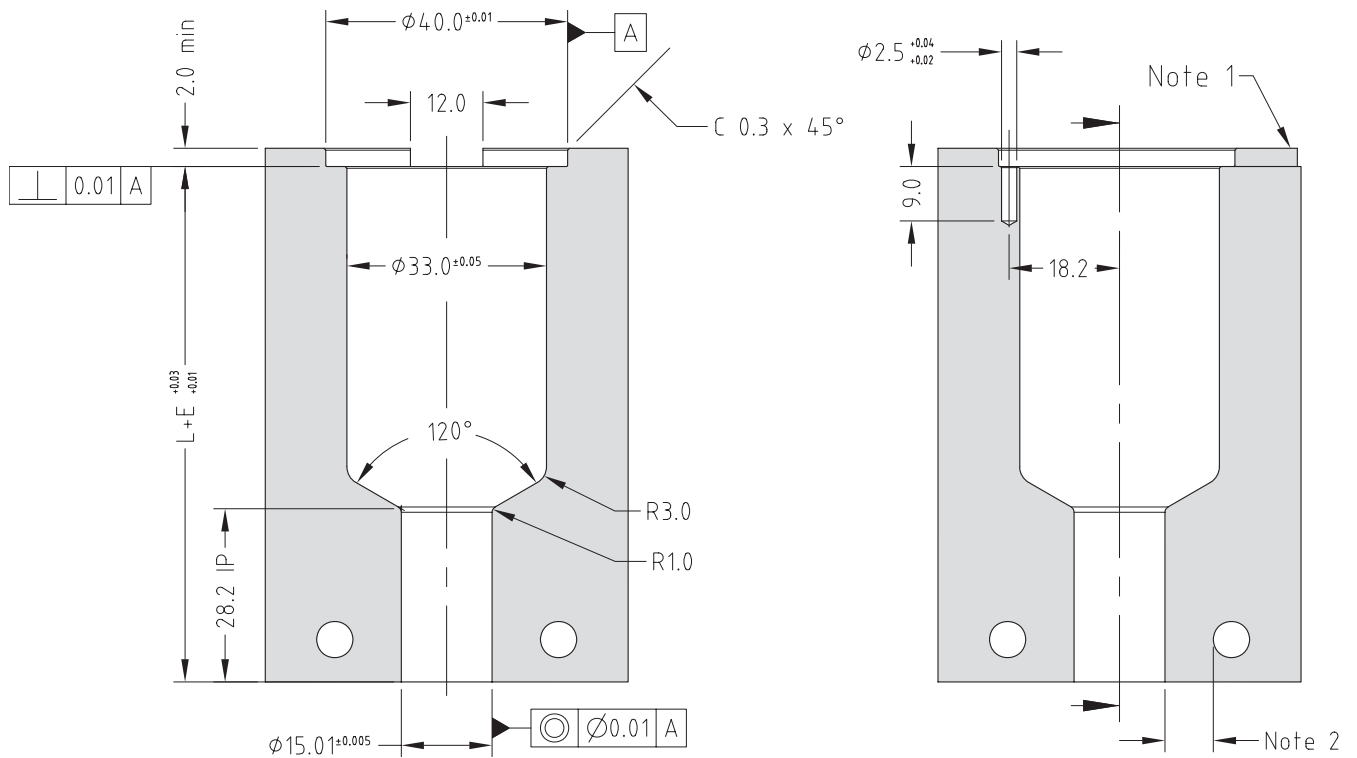

Note

1. Wire channel to suit mould.
 2. Gate cooling is critical for correct operation and gate quality. → See Cooling section in Technical Specifications.
 3. Modify gate diameter and land to suit the part. Supplied with $\varnothing 1.2$ → See Gate Modifications in Technical Specifications.
- * Minimum strength (σ_y) of nozzle plate 800MPa.

Tip and Material Grade Availability

Tip (Code)	G1	G2	G5
Multi-hole Torpedo Tip (X 19 TT)	✓	✓	✓
One-hole Torpedo Tip (X 19 IT)	✓	✓	✓
Open Tip (X 19 OT)	✓	✗	✓

To order a nozzle assembly:

Provide the Nozzle Code + Grade
 (Order example: BXISL19175 G5)

To order a tip:

Provide the Tip Code + Grade
 (Order example: X 19 IT G5)

Nozzle Dimensions

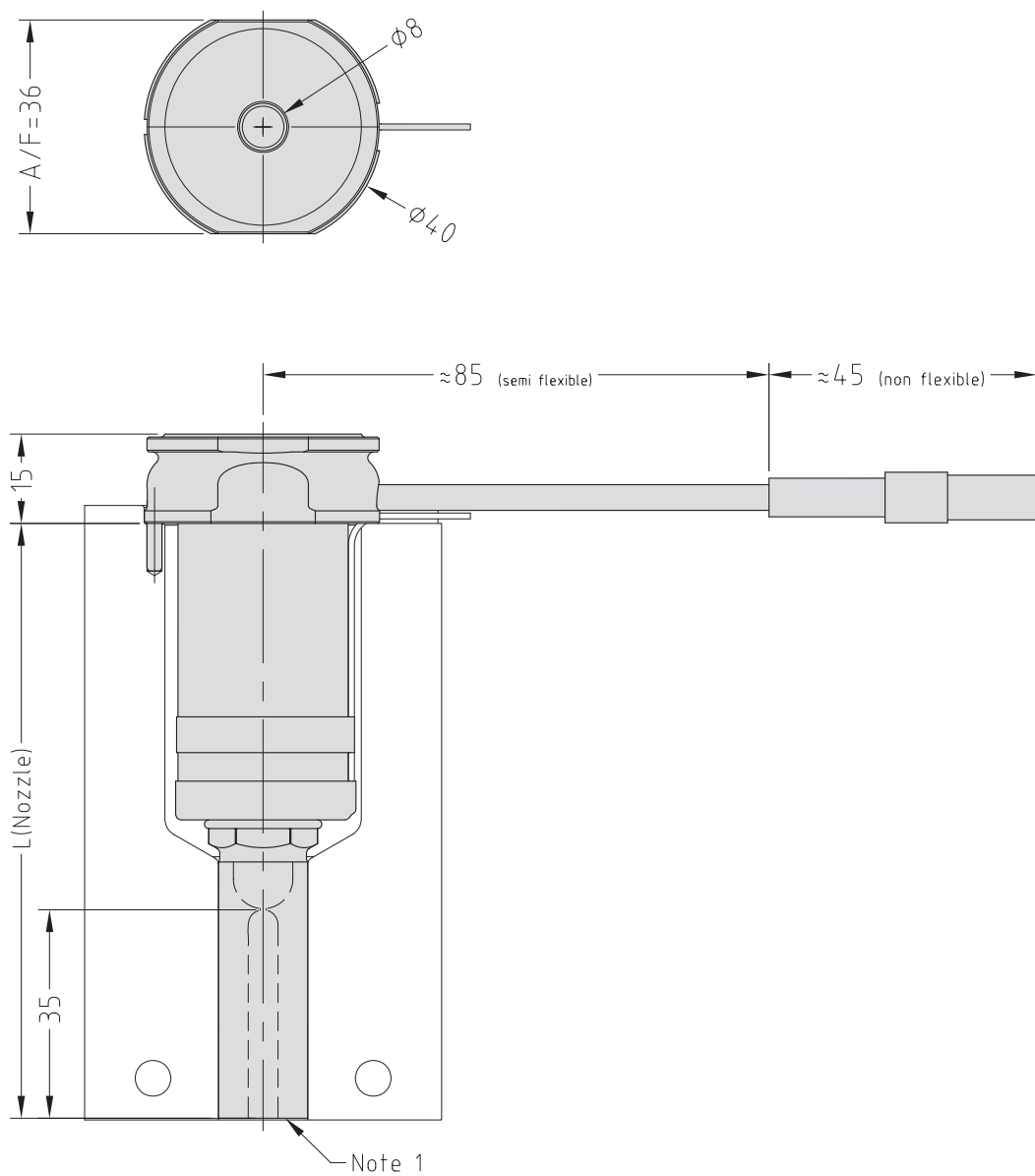

Note

1. Modify the contact area and the sprue nut to suit the application.
 → See Gate Modifications and Cooling sections in the Technical Specifications.

Multi-hole Torpedo Tip Nozzle Code	One-hole Torpedo Tip Nozzle Code	Open Tip Nozzle Code	L	$E_{@200C}$	$E_{@250C}$
BXTSL19055	BXISL19055	BXOSL19055	90.2	0.24	0.30
BXTSL19065	BXISL19065	BXOSL19065	100.2	0.26	0.33
BXTSL19075	BXISL19075	BXOSL19075	110.2	0.29	0.36
BXTSL19095	BXISL19095	BXOSL19095	130.2	0.34	0.43
BXTSL19115	BXISL19115	BXOSL19115	150.2	0.40	0.50
BXTSL19145	BXISL19145	BXOSL19145	180.2	0.48	0.59
BXTSL19175	BXISL19175	BXOSL19175	210.2	0.55	0.69

Nozzle Fitment and Gate Dimensions

$$E = L \times 0.0000132 \times (\text{nozzle temp. } ^\circ\text{C} - \text{mould temp. } ^\circ\text{C})$$

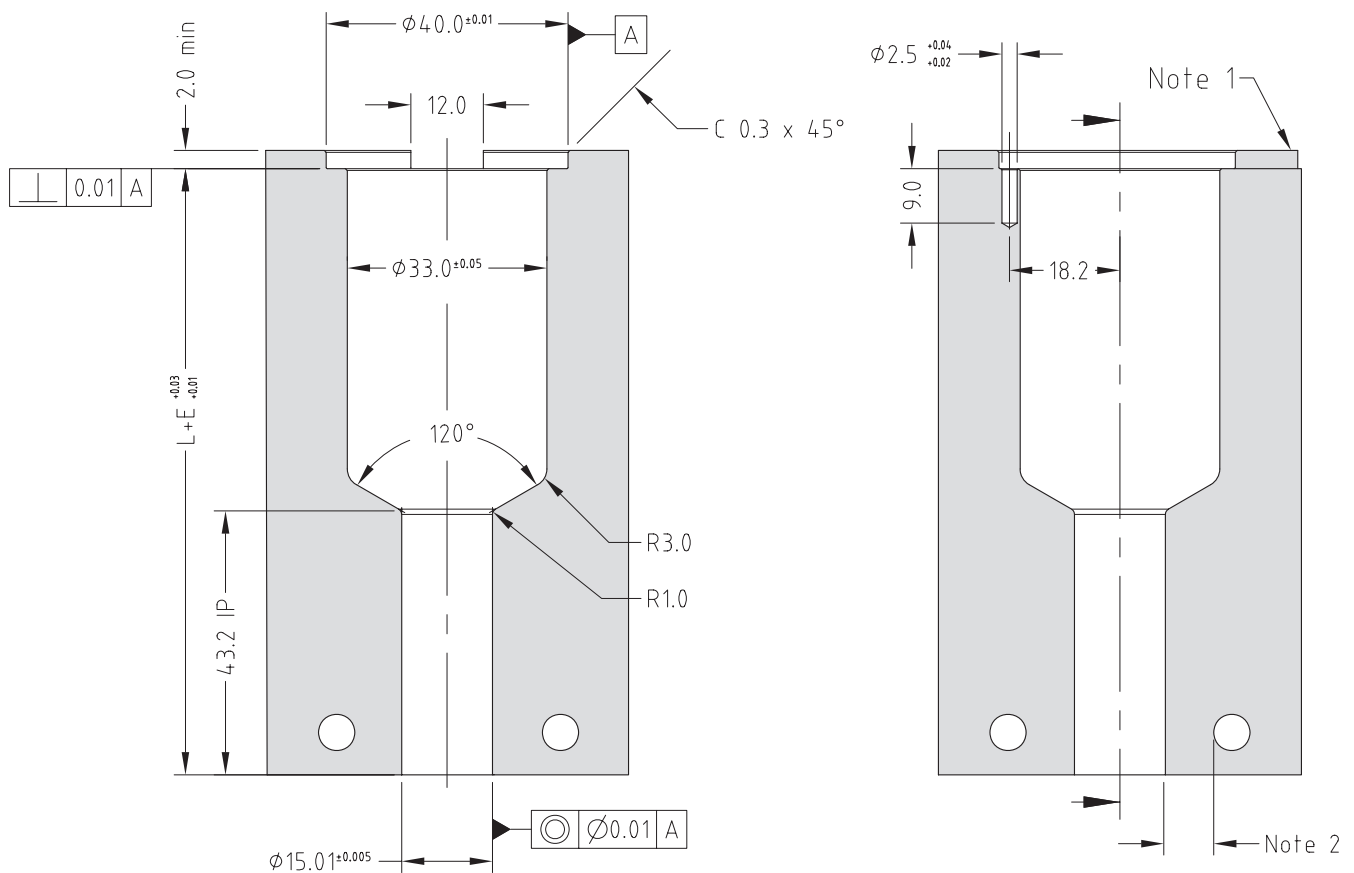

Note

1. Wire channel to suit mould.
 2. Gate cooling is critical for correct operation and gate quality. → See Cooling section in Technical Specifications.
 3. Modify gate diameter and land to suit the part. Supplied with $\varnothing 1.2$ → See Gate Modifications in Technical Specifications.
- * Minimum strength (σ_y) of nozzle plate 800MPa.

Tip and Material Grade Availability

Tip (Code)	G1	G2	G5
Multi-hole Torpedo Tip (X 19 TT+5)	✓	✓	✗
One-hole Torpedo Tip (X 1 IT+5)	✓	✓	✗
Open Tip	✗	✗	✗

To order a nozzle assembly:

Provide the Nozzle Code + Grade
(Order example: BXIT19175+5 G1)

To order a tip:

Provide the Tip Code + Grade
(Order example: X 19 IT+5 G1)

Nozzle Dimensions

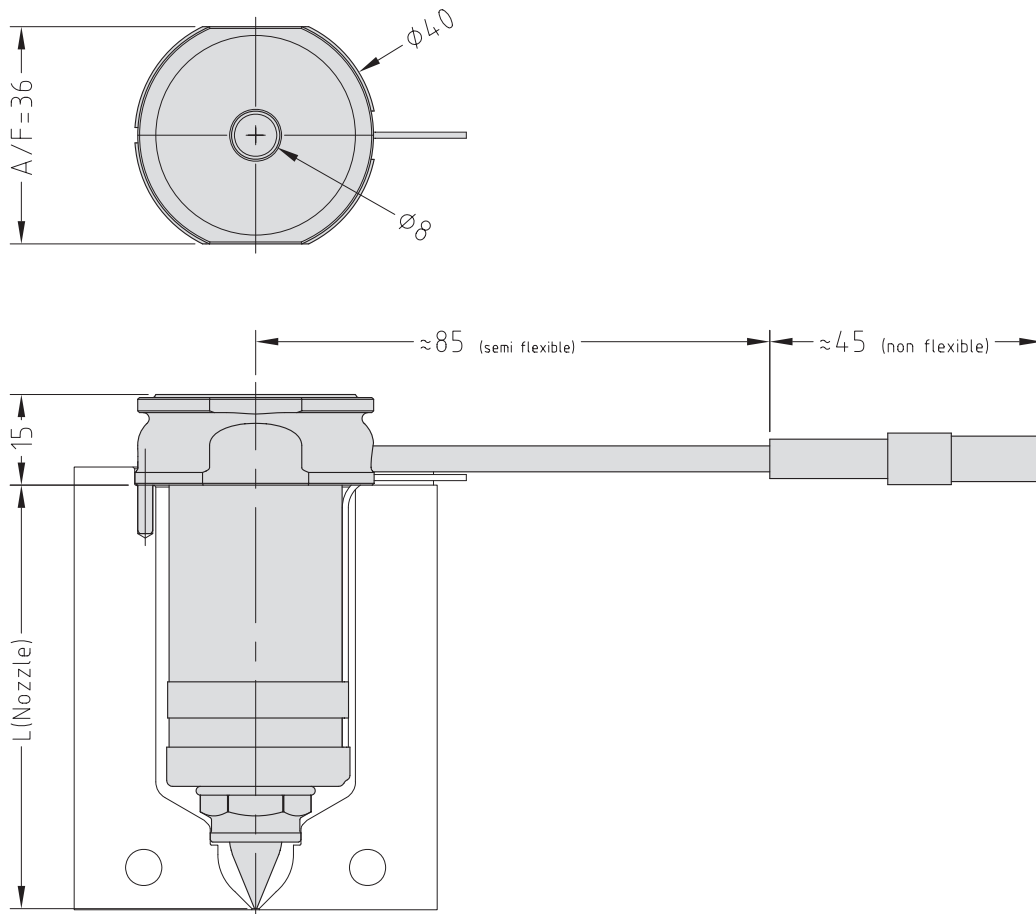

Multi-hole Torpedo Tip Nozzle Code	One-hole Torpedo Tip Nozzle Code	L	E@ΔT =200C	E@ΔT =250C
BXTT19055+5	BXIT19055+5	60	0.16	0.20
BXTT19065+5	BXIT19065+5	70	0.18	0.23
BXTT19075+5	BXIT19075+5	80	0.21	0.26
BXTT19095+5	BXIT19095+5	100	0.26	0.33
BXTT19115+5	BXIT19115+5	120	0.32	0.40
BXTT19145+5	BXIT19145+5	150	0.40	0.50
BXTT19175+5	BXIT19175+5	180	0.48	0.59

Nozzle Fitment and Gate Dimensions

$$E = L \times 0.0000132 \times (\text{nozzle temp. } ^\circ\text{C} - \text{mould temp. } ^\circ\text{C})$$

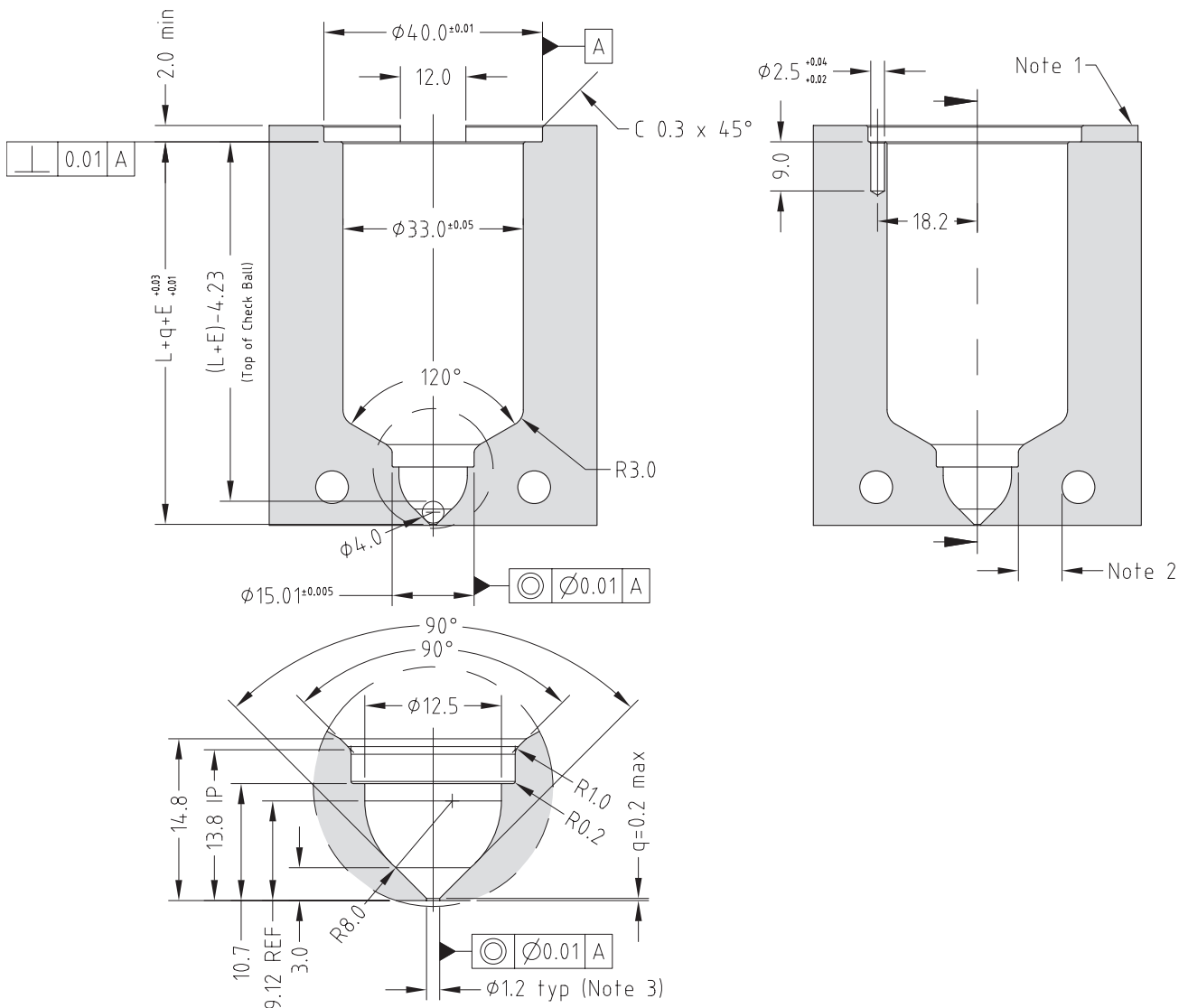

Note

1. Wire channel to suit mould.
 2. Gate cooling is critical for correct operation and gate quality. → See Cooling section in Technical Specifications.
 3. Modify gate diameter and land to suit the part. → See Gate Modifications in Technical Specifications.
- * Minimum strength (σ_y) of nozzle plate 800MPa.

Tip and Material Grade Availability

Tip (Code)	G1	G2	G5
Multi-hole Torpedo Tip (X 19 TT+10)	✓	✓	✗
One-hole Torpedo Tip (X 1 IT+10)	✓	✓	✗
Open Tip	✗	✗	✗

To order a nozzle assembly:

Provide the Nozzle Code + Grade
(Order example: BXIT19175+10 G1)

To order a tip:

Provide the Tip Code + Grade
(Order example: X 19 IT+10 G1)

Nozzle Dimensions

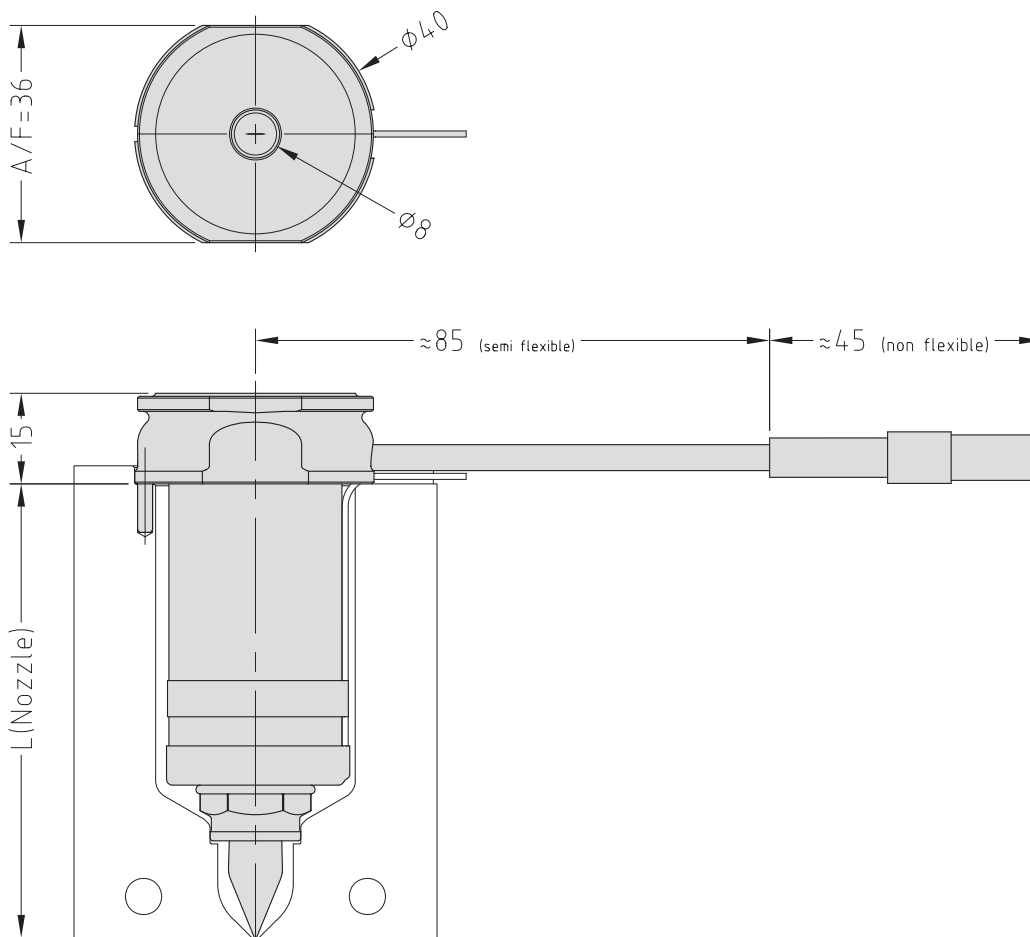

Multi-hole Torpedo Tip Nozzle Code	One-hole Torpedo Tip Nozzle Code	L	$E\theta\Delta T$ =200C	$E\theta\Delta T$ =250C
BXTT19055+10	BXIT19055+10	65	0.17	0.21
BXTT19065+10	BXIT19065+10	75	0.20	0.25
BXTT19075+10	BXIT19075+10	85	0.22	0.28
BXTT19095+10	BXIT19095+10	105	0.28	0.35
BXTT19115+10	BXIT19115+10	125	0.33	0.41
BXTT19145+10	BXIT19145+10	155	0.41	0.51
BXTT19175+10	BXIT19175+10	185	0.49	0.61

Nozzle Fitment and Gate Dimensions

$$E = L \times 0.0000132 \times (\text{nozzle temp. } ^\circ\text{C} - \text{mould temp. } ^\circ\text{C})$$

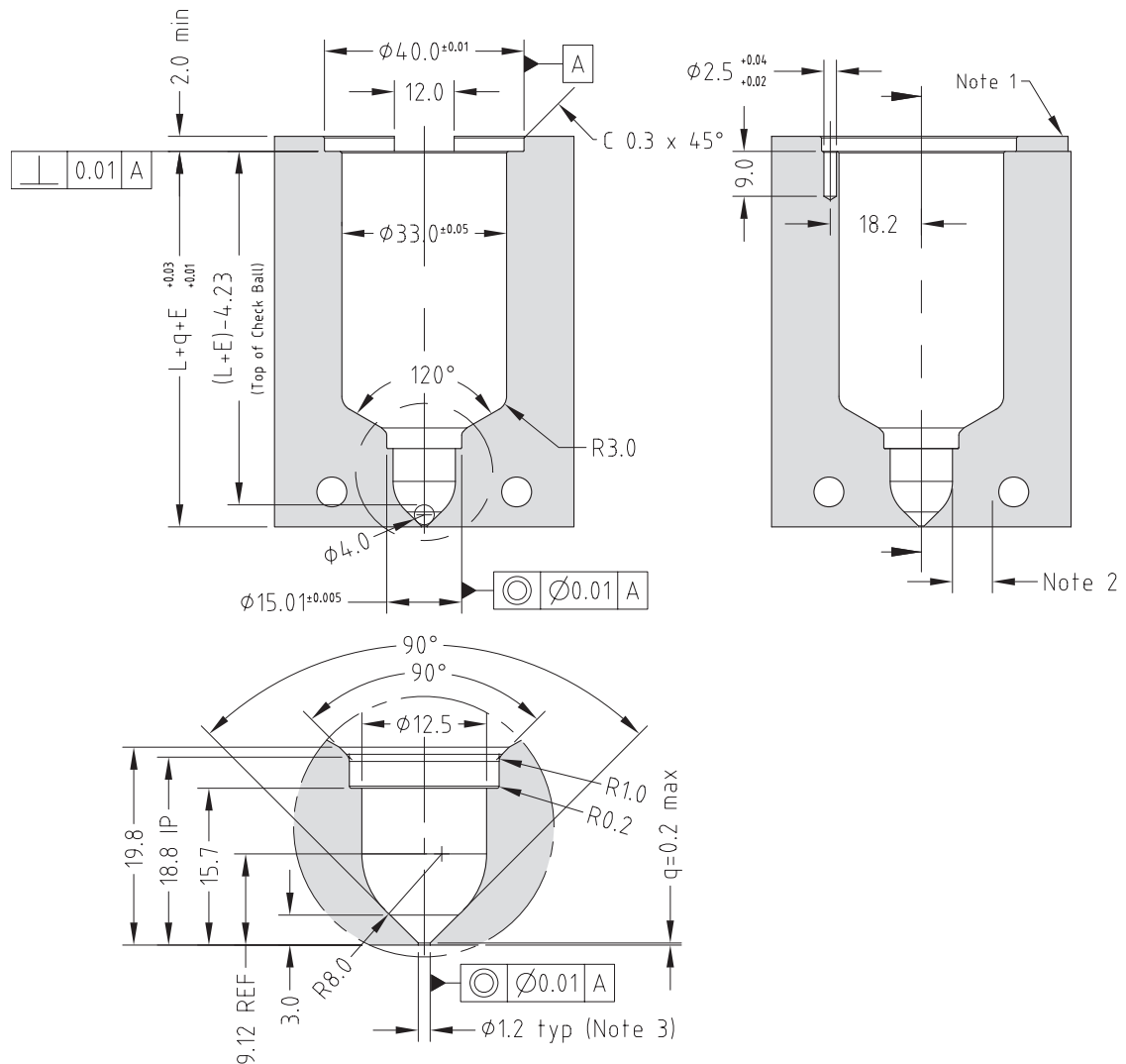

Note

1. Wire channel to suit mould.
2. Gate cooling is critical for correct operation and gate quality. → See Cooling section in Technical Specifications.
3. Modify gate diameter and land to suit the part. → See Gate Modifications in Technical Specifications.

* Minimum strength (σ_y) of nozzle plate 800MPa.

Mastip Head Office New Zealand

558 Rosebank Road
Avondale 1026, Auckland
PO Box 90-651
Victoria Street West
Auckland 1142
New Zealand
Phone: +64 9 970 2100
Fax: +64 9 970 2070
Email: mastip@mastip.com

Mastip Regional Office Europe

Phone: +33 4 724 72 800
Fax: +33 4 724 72 801
Email: europe@mastip.com

Mastip Regional Office China

Phone: +86 21 644 77838
Fax: +86 21 644 77828
Email: china@mastip.com

Mastip Regional Office North America

Phone: +1 262 644 9400
Fax: +1 262 644 9402
Email: northamerica@mastip.com

40-000-020 V1.03



BXTG27



smart hot runner solutions

www.mastip.com

Tip and Material Grade Availability

Tip (Code)	G1	G2	G5
Multi-hole Torpedo Tip (X 27 TT)	✓	✓	✓
One-hole Torpedo Tip (X 27 IT)	✓	✓	✓
Open Tip (X 27 OT)	✓	×	✓

To order a nozzle assembly:

Provide the Nozzle Code + Grade
(Order example: BXIT27175 G5)

To order a tip:

Provide the Tip Code + Grade
(Order example: X 27 IT G5)

Nozzle Dimensions

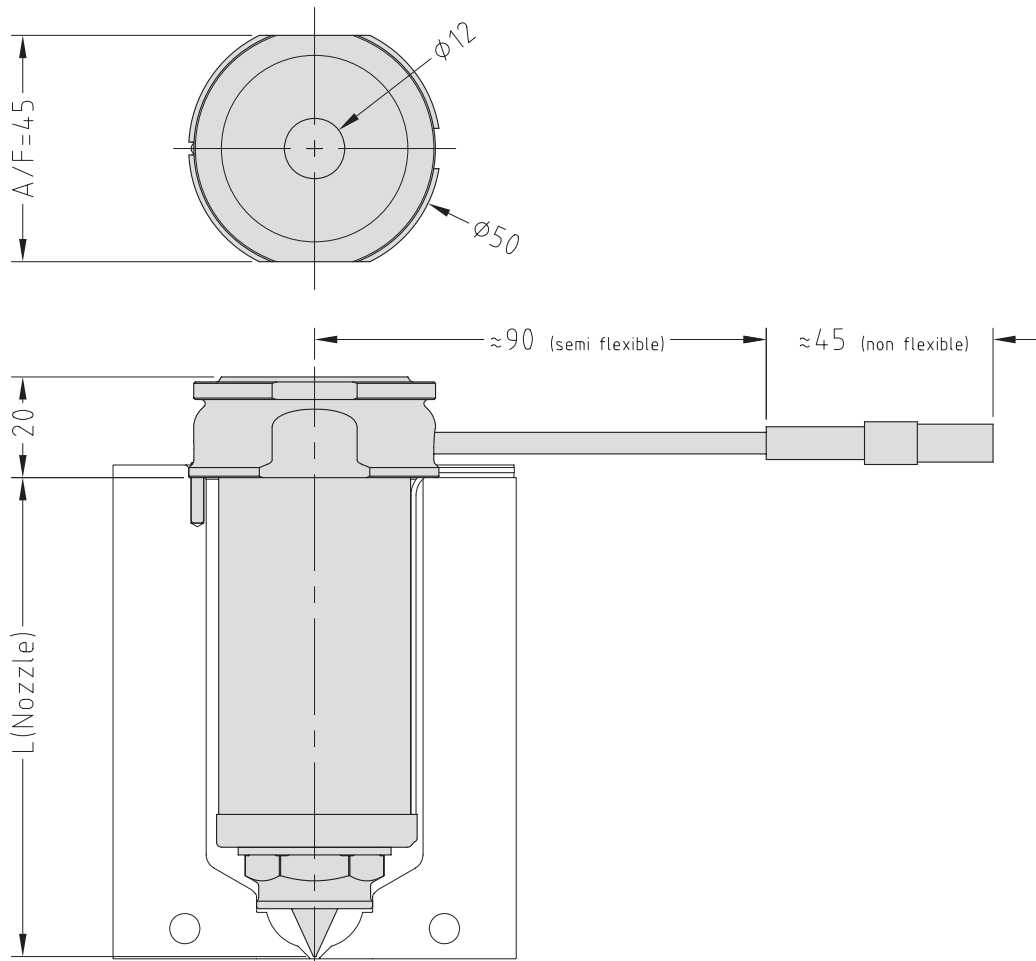

Multi-Hole Torpedo Nozzle Code	One-hole Torpedo Nozzle Code	Open Tip Nozzle Code	L	E@ΔT =200C	E@ΔT =250C
BXTT27075	BXIT27075	BXOT27075	75	0.20	0.25
BXTT27095	BXIT27095	BXOT27095	95	0.25	0.31
BXTT27115	BXIT27115	BXOT27115	115	0.30	0.38
BXTT27145	BXIT27145	BXOT27145	145	0.38	0.48
BXTT27175	BXIT27175	BXOT27175	175	0.46	0.58
BXTT27225	BXIT27225	BXOT27225	225	0.59	0.74
BXTT27275	BXIT27275	BXOT27275	275	0.73	0.91

Nozzle Fitment and Gate Dimensions

$$E = L \times 0.0000132 \times (\text{nozzle temp. } ^\circ\text{C} - \text{mould temp. } ^\circ\text{C})$$

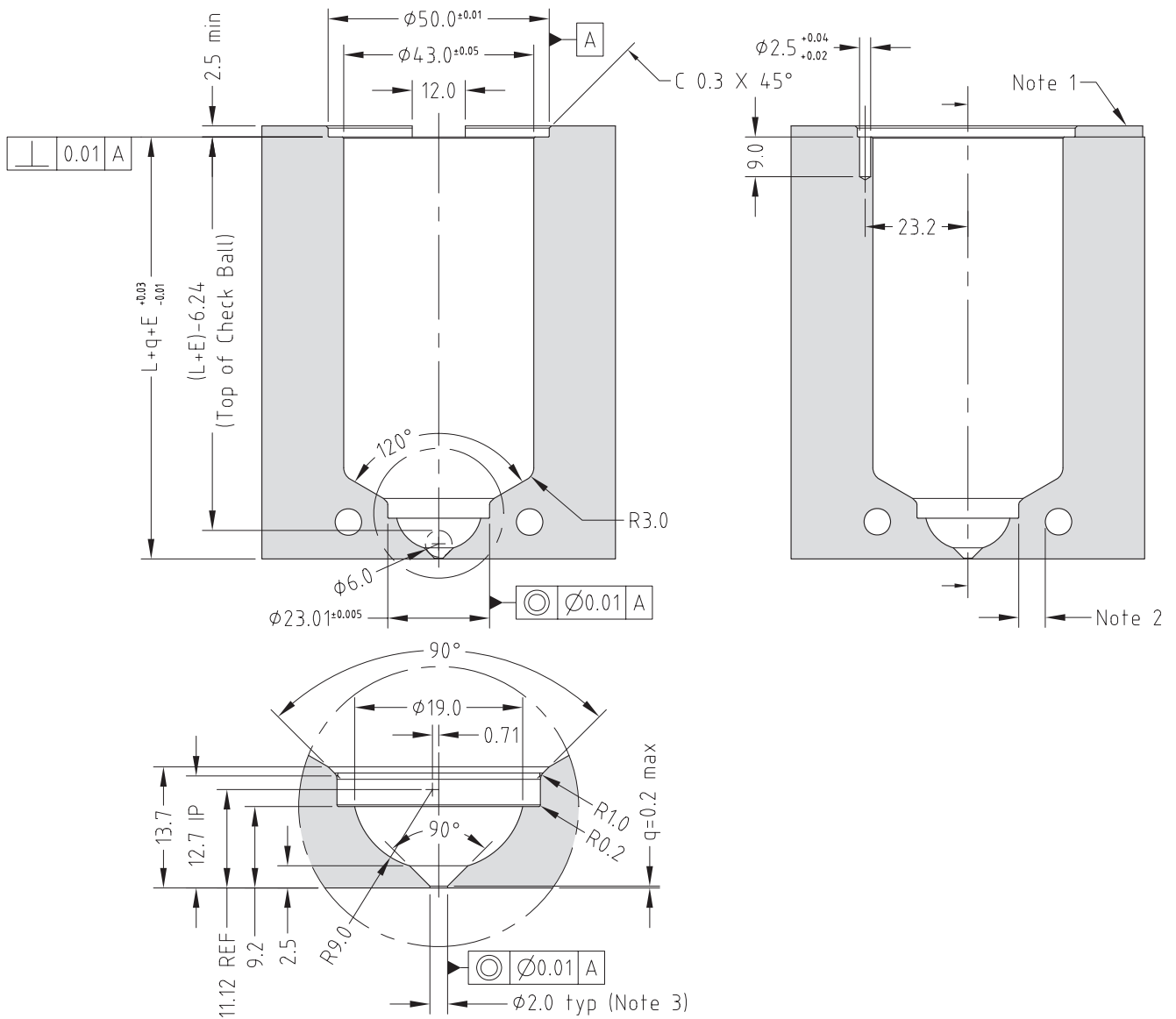

Note

1. Wire channel to suit mould
2. Gate cooling is critical for correct operation and gate quality. → See Cooling section in the Technical Specifications.
3. Modify gate diameter and land to suit the part. → See Gate Modifications in the Technical Specifications.

Tip and Material Grade Availability

Tip (Code)	G1	G2	G5
Multi-hole Torpedo Tip (X 27 TT)	✓	✓	✓
One-hole Torpedo Tip (X 27 IT)	✓	✓	✓
Open Tip (X 27 OT)	✓	×	✓

To order a nozzle assembly:

Provide the Nozzle Code + Grade
(Order example: BXIBN27175 G5)

To order a tip:

Provide the Tip Code + Grade
(Order example: X 27 IT G5)

Nozzle Dimensions

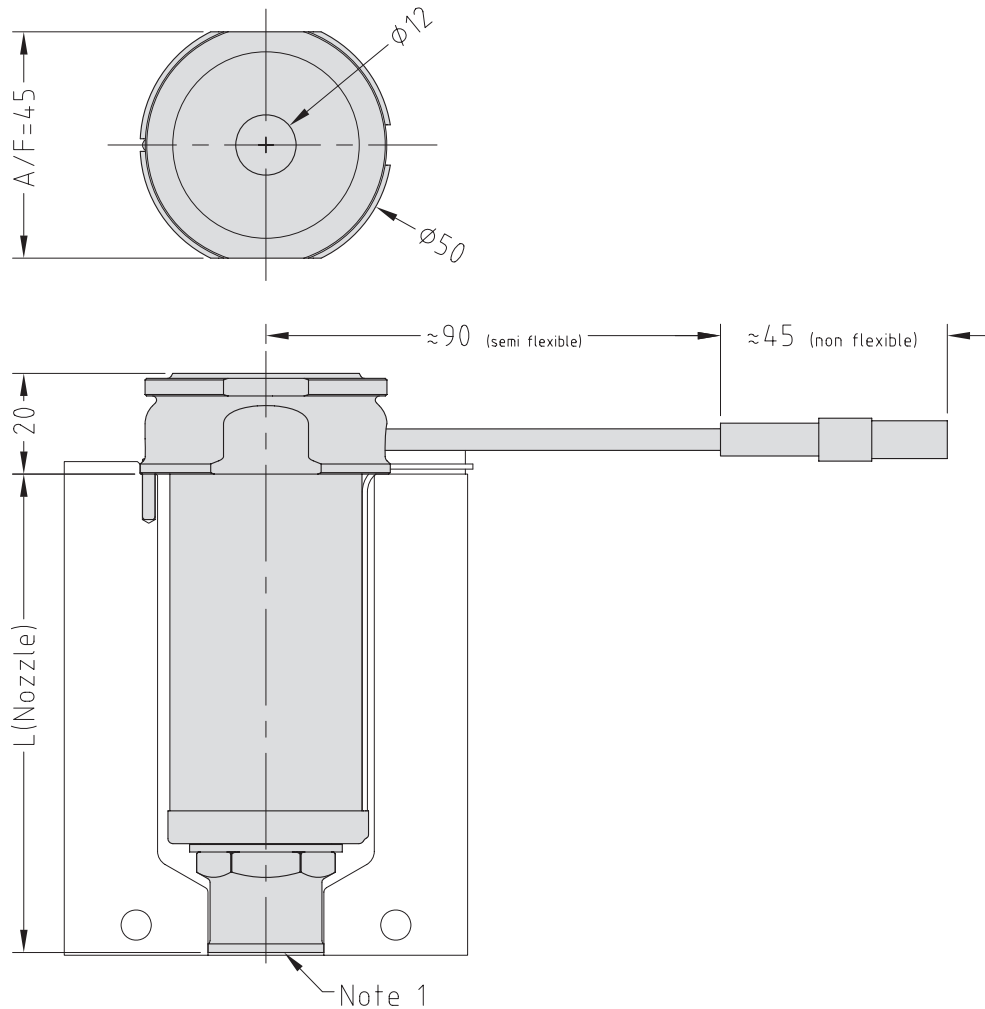
**Note**

1. Modify the contact area to suit the application.

→ See Gate Modifications and Cooling sections in the Technical Specifications.

Multi-Hole Torpedo Nozzle Code	One-hole Torpedo Nozzle Code	Open Tip Nozzle Code	L	E@ΔT =200C	E@ΔT =250C
BXTBN27075	BXIBN27075	BXOBN27075	75.2	0.20	0.25
BXTBN27095	BXIBN27095	BXOBN27095	95.2	0.25	0.31
BXTBN27115	BXIBN27115	BXOBN27115	115.2	0.30	0.38
BXTBN27145	BXIBN27145	BXOBN27145	145.2	0.38	0.48
BXTBN27175	BXIBN27175	BXOBN27175	175.2	0.46	0.58
BXTBN27225	BXIBN27225	BXOBN27225	225.2	0.60	0.74
BXTBN27275	BXIBN27275	BXOBN27275	275.2	0.73	0.91

Nozzle Fitment and Gate Dimensions

$$E = L \times 0.0000132 \times (\text{nozzle temp. } ^\circ\text{C} - \text{mould temp. } ^\circ\text{C})$$

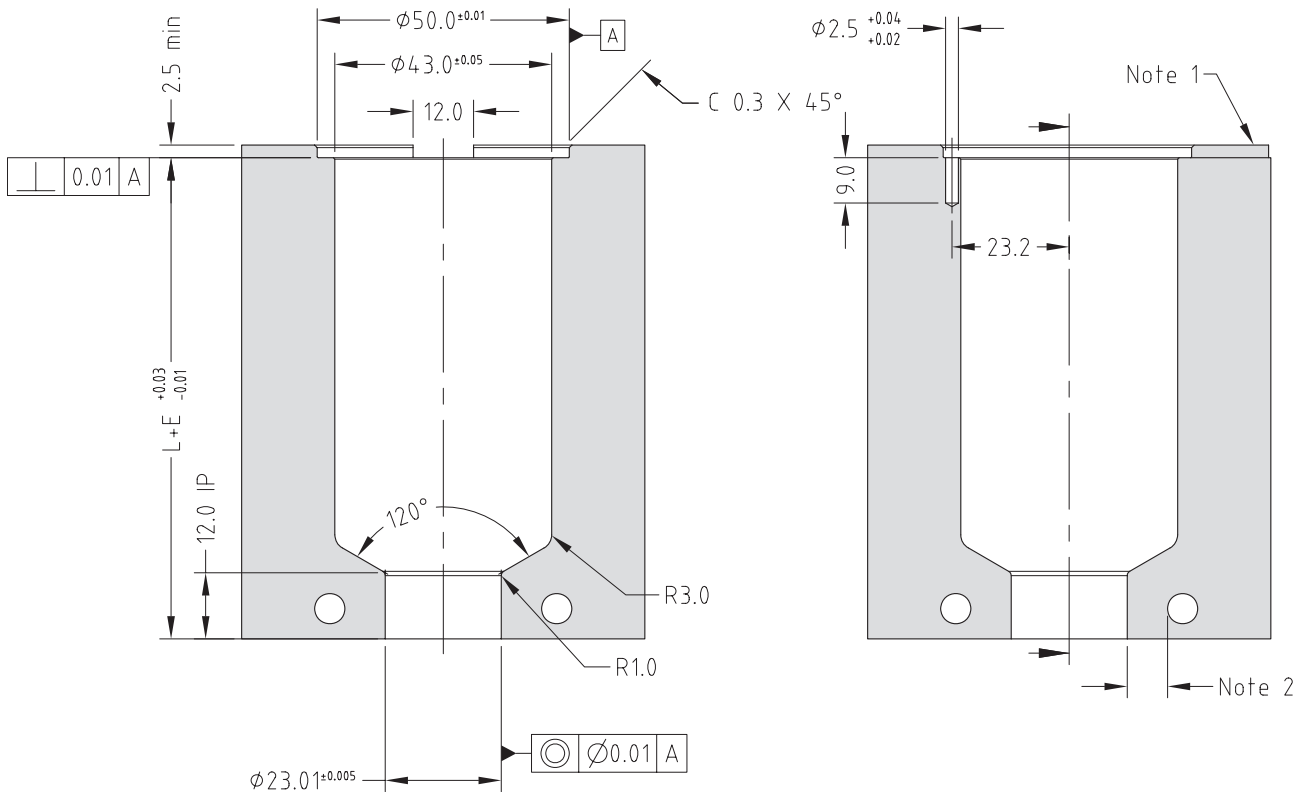

Note

1. Wire channel to suit mould.
2. Gate cooling is critical for correct operation and gate quality. → See Cooling section in the Technical Specifications.
3. Modify gate diameter and land to suit the part. Supplied with $\varnothing 2.0$ → See Gate Modifications in the Technical Specifications.

Tip and Material Grade Availability

Tip (Code)	G1	G2	G5
Multi-hole Torpedo Tip (X 27 TT)	✓	✓	✓
One-hole Torpedo Tip (X 27 IT)	✓	✓	✓
Open Tip (X 27 OT)	✓	×	✓

To order a nozzle assembly:

Provide the Nozzle Code + Grade
(Order example: BXISN27175 G5)

To order a tip:

Provide the Tip Code + Grade
(Order example: X 27 IT G5)

Nozzle Dimensions

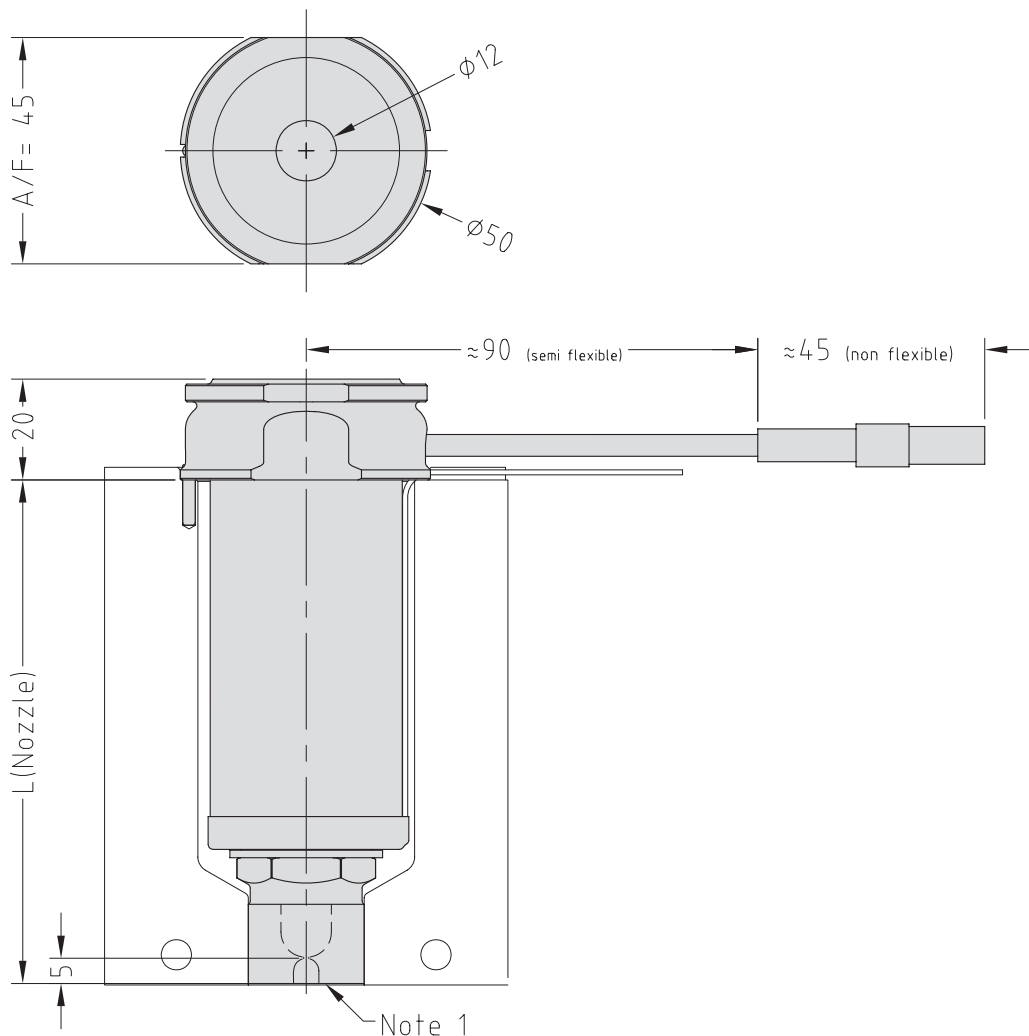
**Note**

1. Modify the contact area and the sprue nut to suit the application.
→ See Gate Modifications and Cooling sections in the Technical Specifications.

Tip and Material Grade Availability

Tip (Code)	G1	G2	G5
Multi-hole Torpedo Tip (X 27 TT)	✓	✓	✓
One-hole Torpedo Tip (X 27 IT)	✓	✓	✓
Open Tip (X 27 OT)	✓	✗	✓

To order a nozzle assembly:

Provide the Nozzle Code + Grade
(Order example: BXISL27175 G5)

To order a tip:

Provide the Tip Code + Grade
(Order example: X 27 IT G5)

Nozzle Dimensions

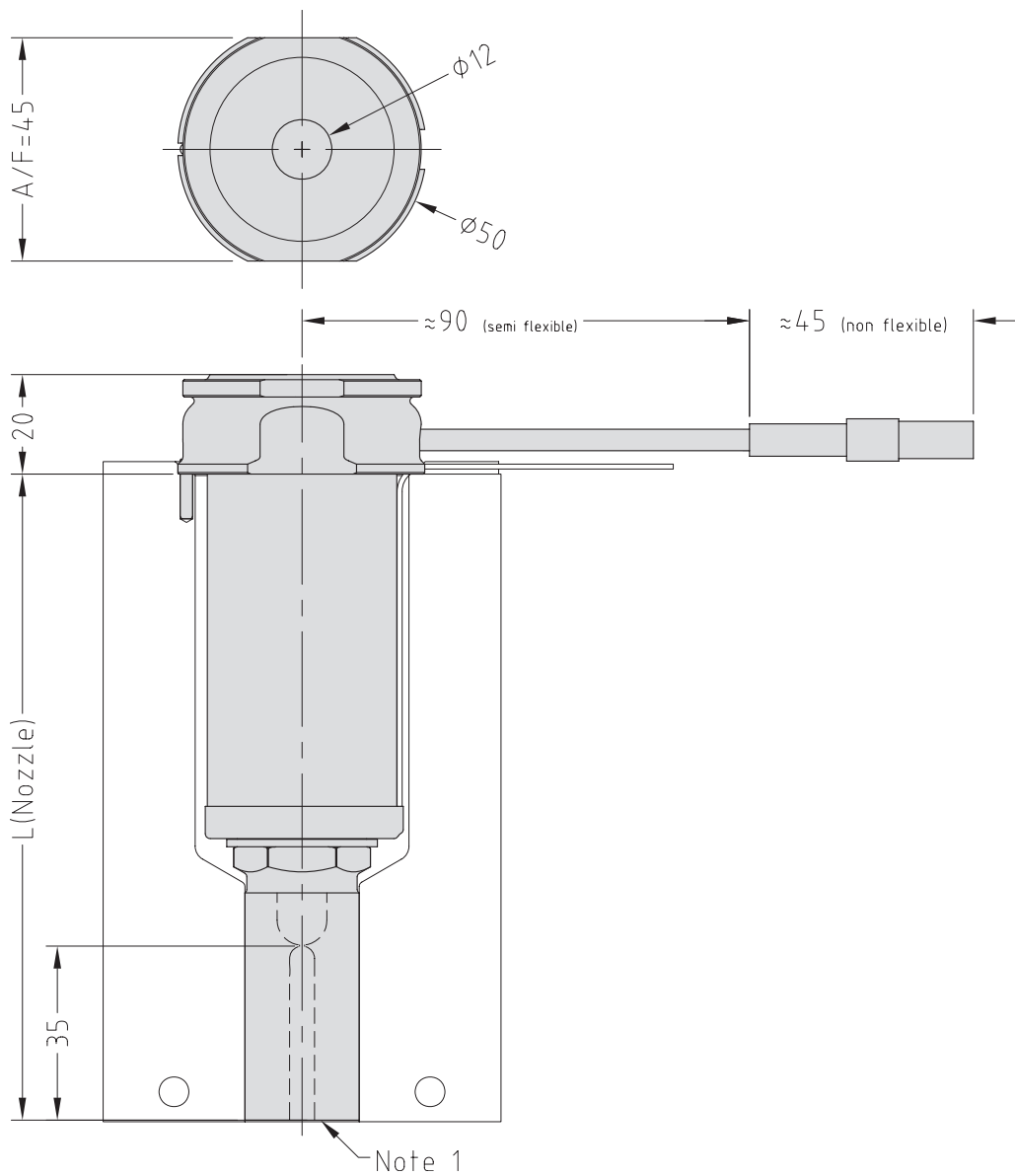

Note

1. Modify the contact area and the sprue nut to suit the application.
→ See Gate Modifications and Cooling sections in the Technical Specifications.

Multi-Hole Torpedo Nozzle Code	One-hole Torpedo Nozzle Code	Open Tip Nozzle Code	L	E@ΔT =200C	E@ΔT =250C
BXTSL27075	BXISL27075	BXOSL27075	110.2	0.29	0.36
BXTSL27095	BXISL27095	BXOSL27095	130.2	0.34	0.43
BXTSL27115	BXISL27115	BXOSL27115	150.2	0.40	0.50
BXTSL27145	BXISL27145	BXOSL27145	180.2	0.48	0.59
BXTSL27175	BXISL27175	BXOSL27175	210.2	0.55	0.69
BXTSL27225	BXISL27225	BXOSL27225	260.2	0.69	0.86
BXTSL27275	BXISL27275	BXOSL27275	310.2	0.82	1.02

Nozzle Fitment and Gate Dimensions

$E = L \times 0.000132 \times (\text{nozzle temp. } ^\circ\text{C} - \text{mould temp. } ^\circ\text{C})$

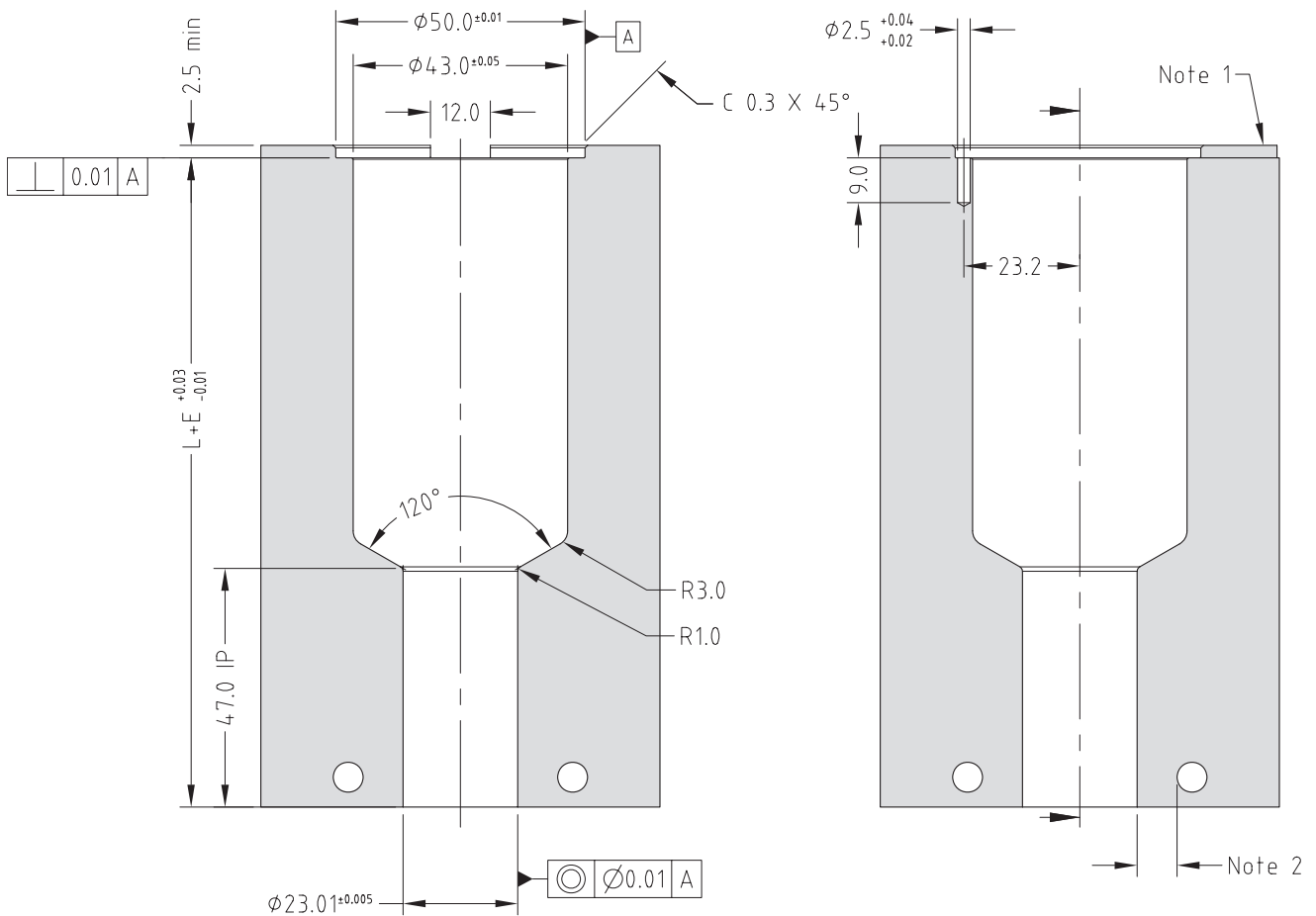

Note

1. Wire channel to suit mould.
2. Gate cooling is critical for correct operation and gate quality. → See Cooling section in the Technical Specifications.
3. Modify gate diameter and land to suit the part. Supplied with Ø2.0 → See Gate Modifications in the Technical Specifications.

Tip and Material Grade Availability

Tip (Code)	G1	G2	G5
Multi-hole Torpedo Tip (X 27 TT+10)	✓	✓	✗
One-hole Torpedo Tip (X 27 IT+10)	✓	✓	✗
Open Tip	✗	✗	✗

To order a nozzle assembly:

Provide the Nozzle Code + Grade
(Order example: BXIT27175+10 G2)

To order a tip:

Provide the Tip Code + Grade
(Order example: X 27 IT+10 G2)

Nozzle Dimensions

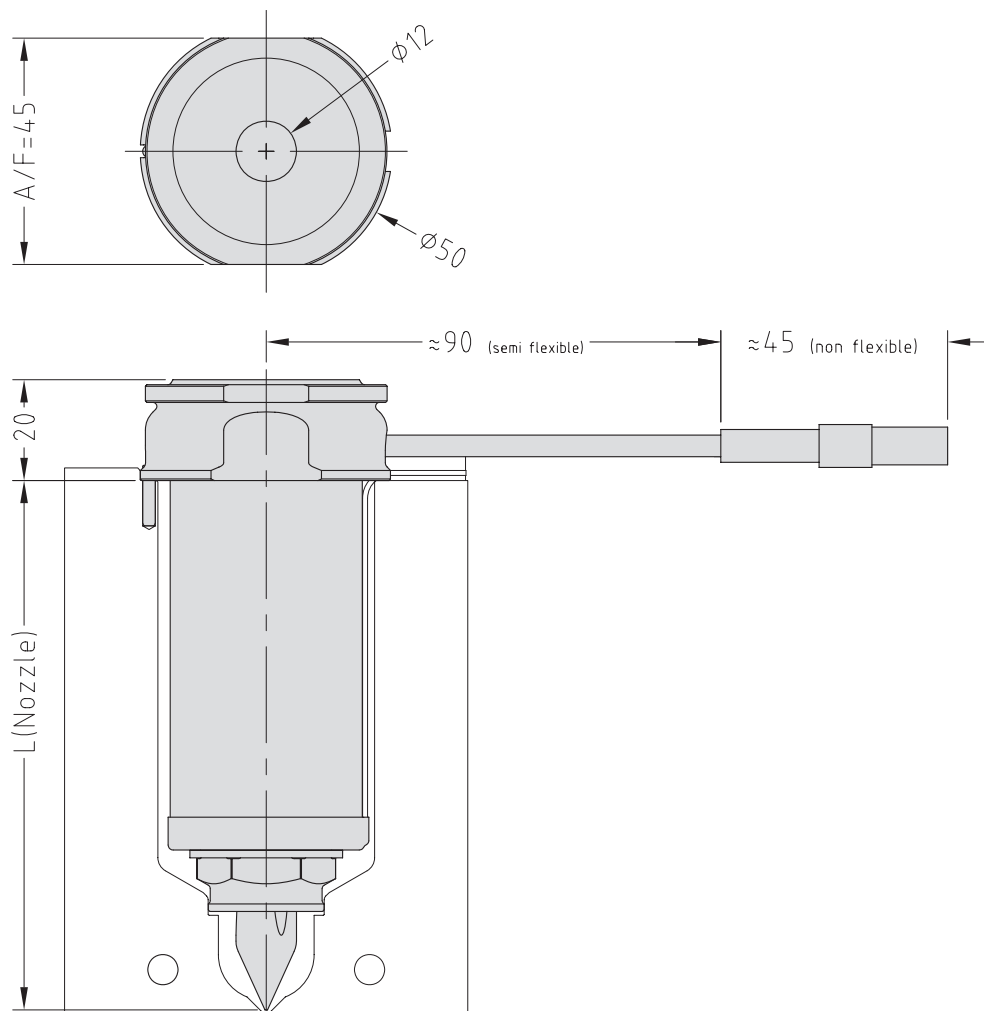

Multi-Hole Torpedo Nozzle Code	One-hole Torpedo Nozzle Code	L	E@ΔT =200C	E@ΔT =250C
BXTT27075+10	BXIT27075+10	85	0.22	0.28
BXTT27095+10	BXIT27095+10	105	0.28	0.35
BXTT27115+10	BXIT27115+10	125	0.33	0.41
BXTT27145+10	BXIT27145+10	155	0.41	0.51
BXTT27175+10	BXIT27175+10	185	0.49	0.61
BXTT27225+10	BXIT27225+10	235	0.62	0.76
BXTT27275+10	BXIT27275+10	285	0.75	0.94

Nozzle Fitment and Gate Dimensions

$$E = L \times 0.000132 \times (\text{nozzle temp. } ^\circ\text{C} - \text{mould temp. } ^\circ\text{C})$$

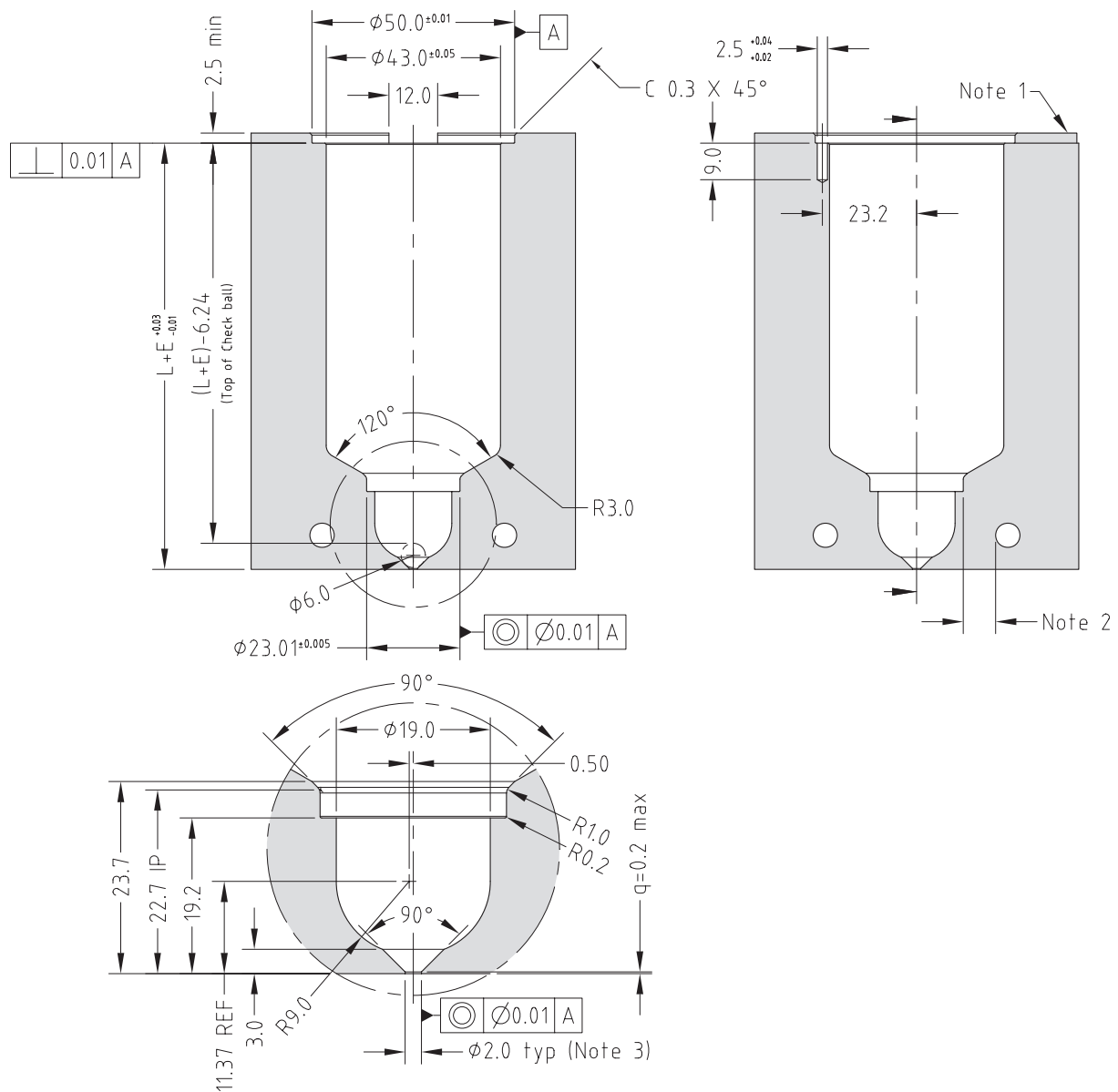

Note

1. Wire channel to suit mould
2. Gate cooling is critical for correct operation and gate quality. → See Cooling section in the Technical Specifications.
3. Modify gate diameter and land to suit the part. → See Gate Modifications in the Technical Specifications.

Mastip Head Office New Zealand

558 Rosebank Road
Avondale 1026, Auckland
PO Box 90-651
Victoria Street West
Auckland 1142
New Zealand
Phone: +64 9 970 2100
Fax: +64 9 970 2070
Email: mastip@mastip.com

Mastip Regional Office Europe

Phone: +33 4 724 72 800
Fax: +33 4 724 72 801
Email: europe@mastip.com

Mastip Regional Office China

Phone: +86 21 644 77838
Fax: +86 21 644 77828
Email: china@mastip.com

Mastip Regional Office North America

Phone: +1 262 644 9400
Fax: +1 262 644 9402
Email: northamerica@mastip.com

40-000-030

V1.03

