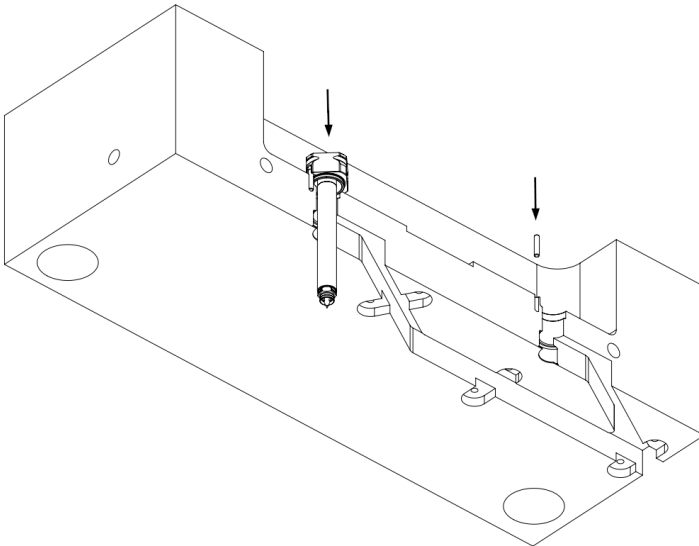
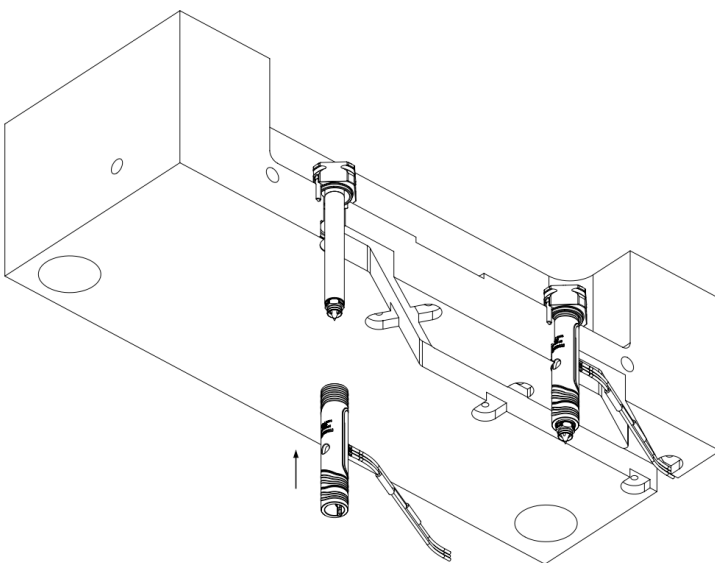

Installation an MX09 Nozzle in a front-loading configuration**ONE**

Fit the dowels into the mould plate.

Fit the nozzle assemblies into the cavity plate.

Check that all nozzles are level within 0.01mm.

TWO

Slide the heaters onto the nozzles.

Thread the wires through the wire channels in the cavity plate.

INSTALLATION CONT.....

THREE

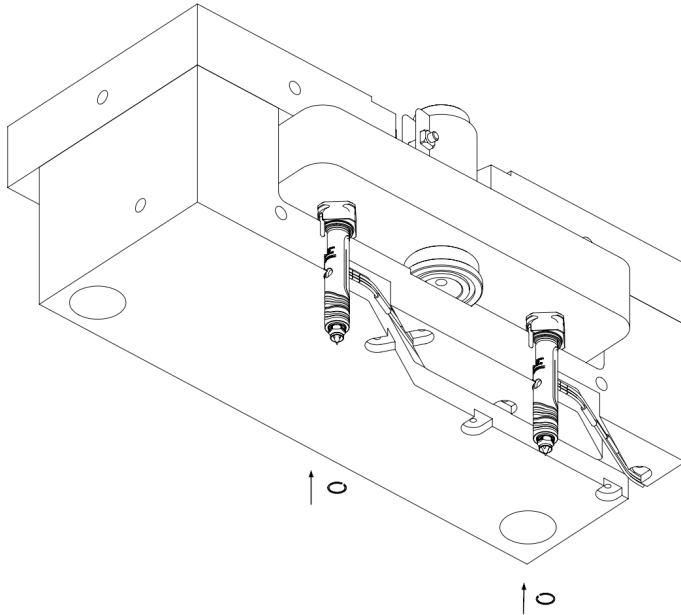

Fit the snap ring.

FOUR

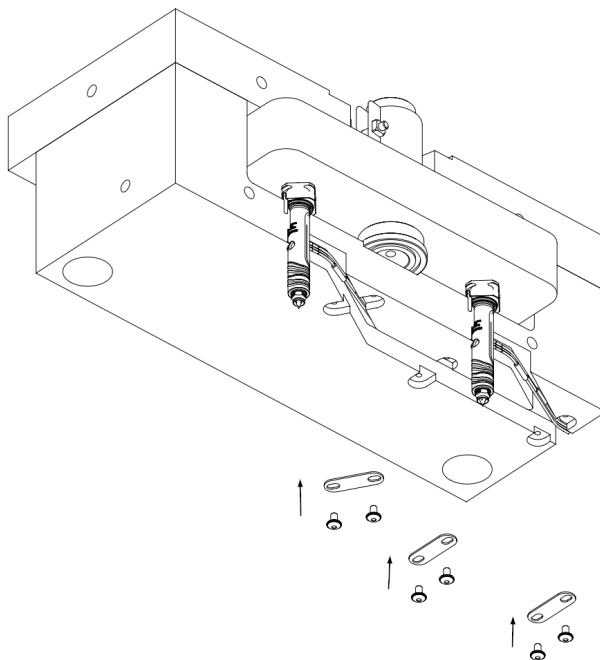

Fasten the wires in the cavity plate wire channel.

REPLACING THE HEATER

ONE

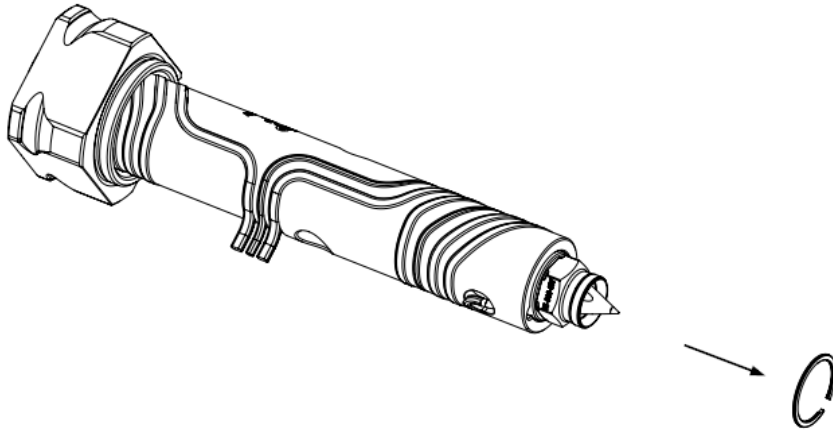

Remove the snap ring.

TWO

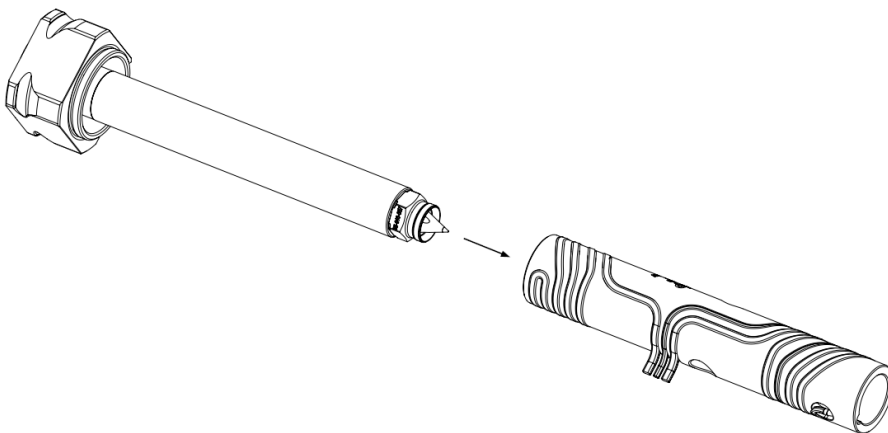

Remove the Heater.

* To reinstall the heater, follow steps 1 and 2 in reverse order.

REPLACING THE TIP AND NUT

ONE

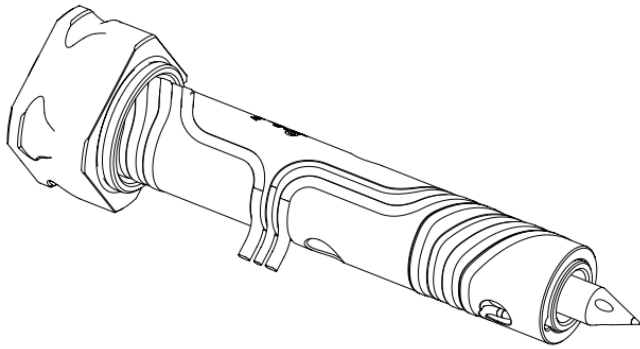

Use a AF8mm socket to unscrew the nut from the body and remove nut and snap ring.

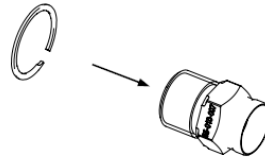

TWO

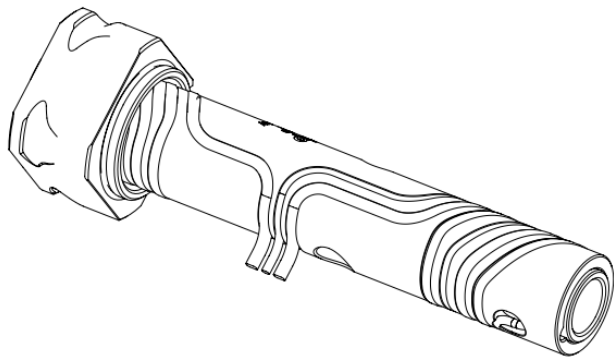

Remove tip from the body.

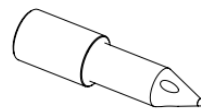

1. Clean any plastic & debris from the tip pocket in the nozzle body.
2. Replace with new tip.
3. Apply a small amount of heat resistant nickel grease to the thread of new nut.
4. Screw the new nut into the body with snap ring and torque to 10Nm.
5. Check that the tip height is correct.

THERMOCOUPLE REPLACEMENT

ONE

Remove the snap ring.

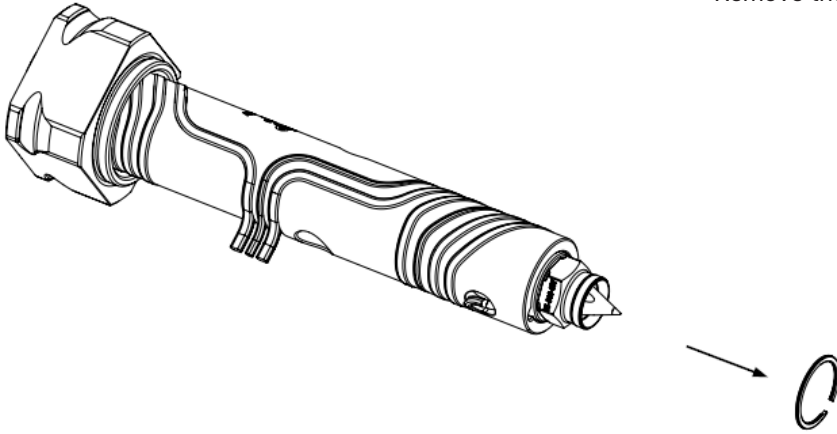

TWO

Remove the Heater.

Remove thermocouple from thermocouple groove.

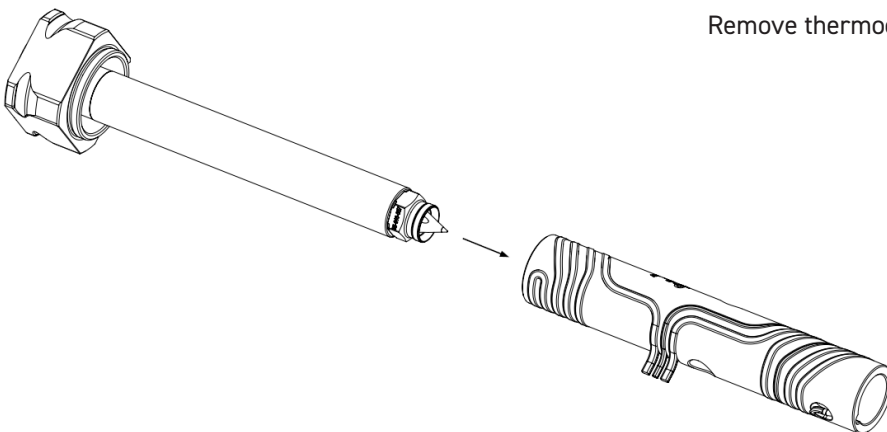

REPLACING CONT.....

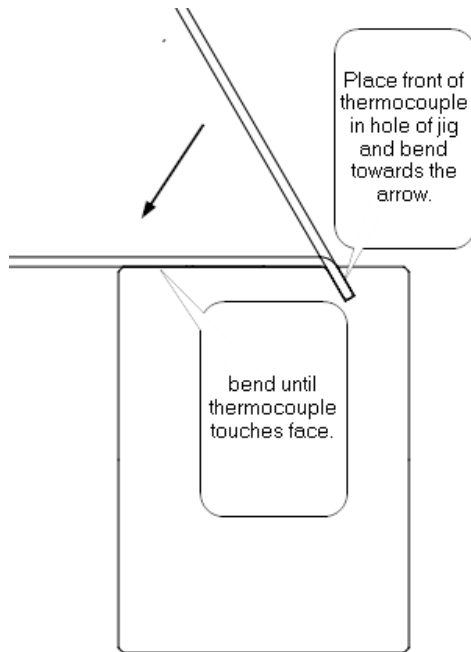
THREE

Pre-bend front of replacement thermocouple with jig (38-010-003).

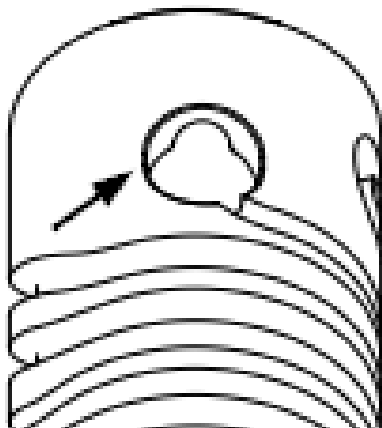
FOUR

Place front bend through thermocouple hole.

REPLACING CONT.....

FIVE

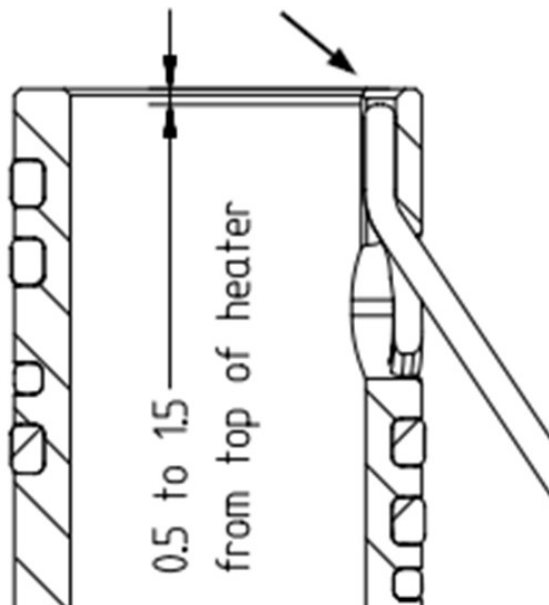

Line up with internal slot.

SIX

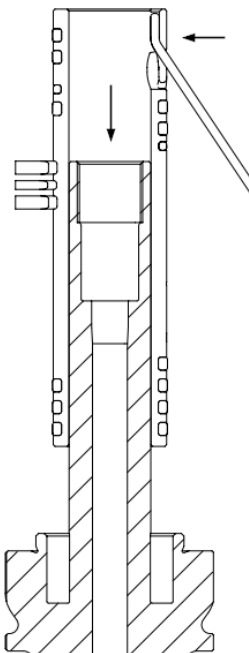

Slide heater over a nozzle body if available or use a rod with a diameter of 9.37mm with a tolerance of ± 0.02 to hold thermocouple front bend in place in the internal slot.

REPLACING CONT.....

SEVEN

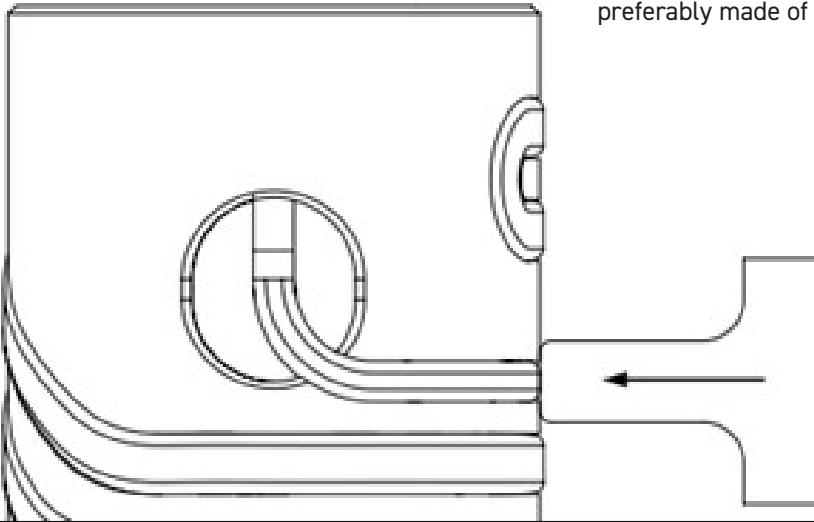

Follow thermocouple groove and gently press replacement thermocouple into place, with flat tool preferably made of brass, that is wider than the groove.

Thermocouple Spare Part Codes

	Thermocouple
57-309-055 (Heater MX09055)	39-810-150
57-309-065 (Heater MX09065)	39-810-180
57-309-075 (Heater MX09075)	39-810-200
57-309-085 (Heater MX09085)	39-810-200
57-309-095 (Heater MX09095)	39-810-250
57-309-105 (Heater MX09105)	39-810-250
57-309-115 (Heater MX09115)	39-810-275
57-309-130 (Heater MX09130)	39-810-275
57-309-145 (Heater MX09145)	39-810-300
57-309-160 (Heater MX09160)	39-810-325
57-309-175 (Heater MX09175)	39-810-325